



**CONTROLLED**

# RHINO-RACK

## Rhino-Rack 2 Hitch Bike RBC045

**Important:** Please read these instructions carefully prior to installation. Please refer to your fitting instruction to ensure that the bike rack is installed in the correct locations. Check the contents of kit before commencing fitment and report any discrepancies. Place these instructions in the vehicle's glove box after installation is complete.

### Layout

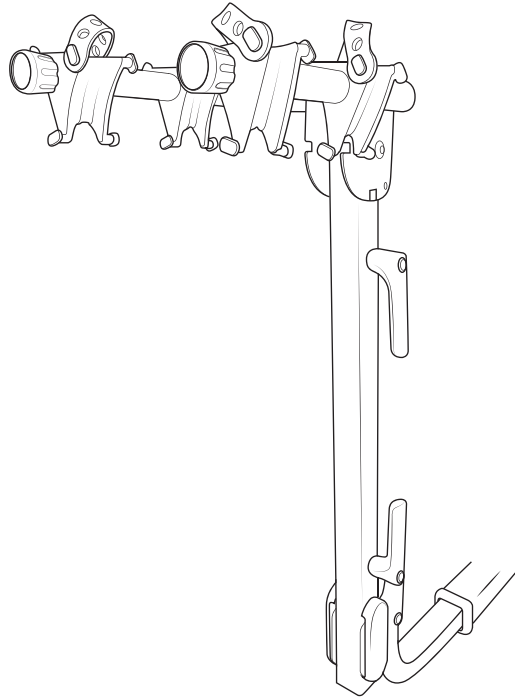

### Important Information

**Maximum carrying capacity: 15kg (33lbs) per bike. Max 2 Bikes. Totalling 30kg/ 66lbs.**

**Warning:** Do not attempt to fit the bike carrier to your vehicle unless you fully understand this fitting instructions. Please direct any questions regarding fitting to the dealer from where the bike carrier was purchased. **Use only non-stretch fastening ropes or straps. For use on vehicle hitch only - DO NOT INSTALL to rear of recreational vehicles.**

#### Recommendations:

It is essential that all bolt connections be checked after driving a short distance when you first install your bike carrier. Bolt connections should be checked again at regular intervals (once a week is enough, depending on road conditions, usage, loads and distances travelled). You should also check the bike carrier each time it is re-fitted. Always make sure to fasten your load securely. Please also ensure that all loads are evenly distributed and that the centre of gravity is kept as low as possible.

**Bike carrier must be removed when putting vehicle through an automatic car wash.**

In some states it may be against the law to obstruct clear view of lamps and registration plates. It is suggested that the Rhino-Rack Number Plate Holder (RBCA011) be purchased.

**Caution:** The handling characteristics of the vehicle changes when you transport a load on the roof or at the rear. For safety reasons we recommend you exercise extreme care when transporting wind-resistant loads. Special consideration must be taken into account when cornering and braking.

#### Note for Dealers and Fitters

It is your responsibility to ensure this fitting instruction is given to the end user or client

Rhino-Rack

3 Pike Street, Rydalmere,

NSW 2116, Australia.

(Ph) (02) 9638 4744

(Fax) (02) 9638 4822

Document No: R1181

Prepared By: Kayle Everett

Authorised By: Chris Murty

Fit Time: 20min

Issue No: 03

Issue Date: 27/12/2017

These instructions remain the property of Rhino-Rack Australia Pty Ltd and may not be used or changed for any other purpose than intended.



# Rhino-Rack 2 Hitch Bike RBC045

Item	Component Name	Qty	Part No.
1	Bike Carrier Body	1	-
2	Rubber Straps	6	-
3	Allen Key (short)	1	-
4	Allen Key (long)	1	-
5	Hitch Pin	1	-
6	Shake Proof Washer	1	-
7a	Flat Washer (1/2")	3	-
7b	Flat Washer (5/16")	1	-
8	Nyloc Nut	1	-
9a	Dome Head Screw	1	-
9b	Dome Head Screw (3")	1	-
10	Retention Strap	1	-
11	Spanner	1	-
12	R-Clip	1	-
13	Instructions	1	R1181

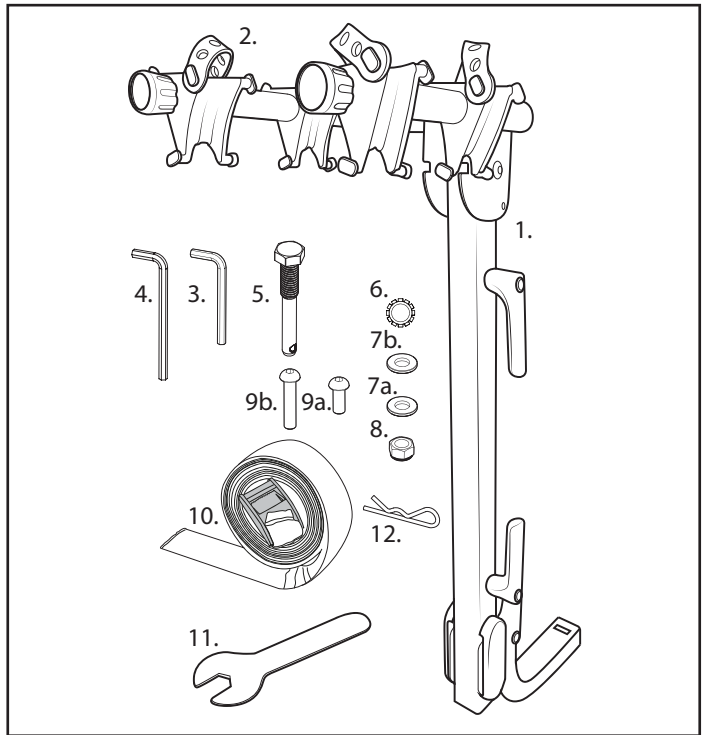

In some states it may be against the law to obstruct clear view of lamps and registration plates. It is suggested that the Rhino-Rack Number Plate Holder (RBCA011) be purchased.

## Instructions

- 1** Insert the lower arm of the bike rack into the main body. Fix in place with hardware as shown.

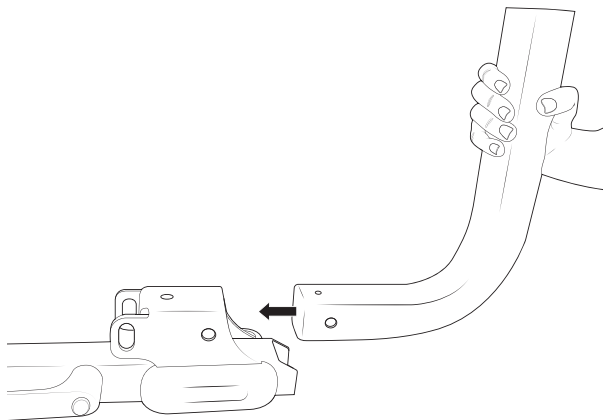

Tighten the dome head screw (9b), flat washers (7a) and nyloc nut hardware in place using the spanner and allen key provided.

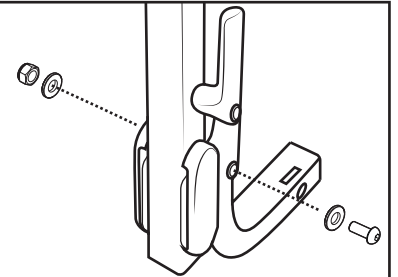

The other dome head screw fits in place at the rear with a flat washer (7b) as shown. Tighten with the allen key provided.

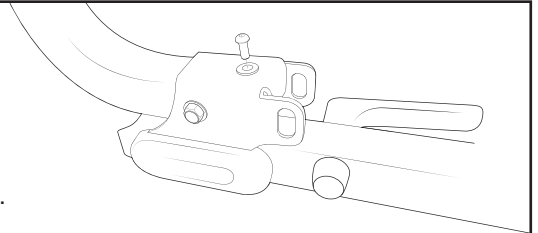

- 2** Insert the bike rack into the Hitch Mount Receiver. Install the 1/2" Hitch Pin and tighten. Lock in place by fixing the R Clip into the end of the Hitch Pin.

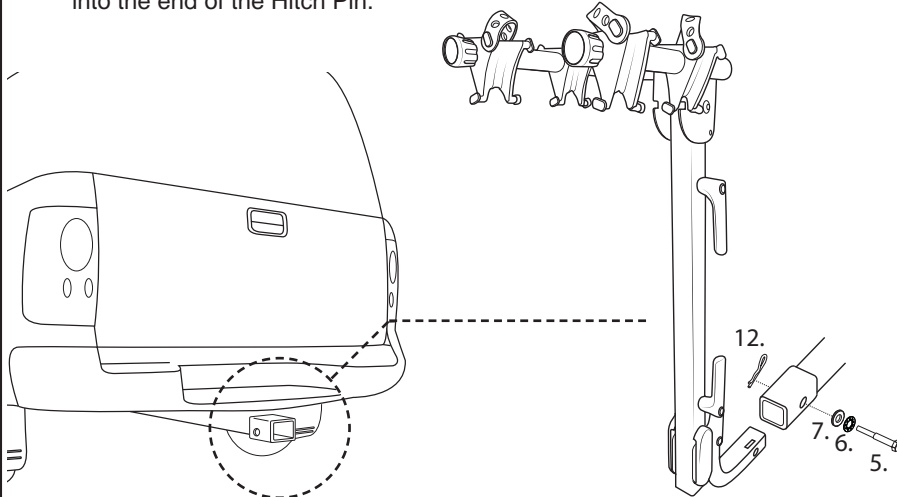

**Note:** Install the pin on the side one the same side as the anti rotation block. When installed correctly, the block will raise up within the hitch and the pin in tightened.

Anti rotation block.

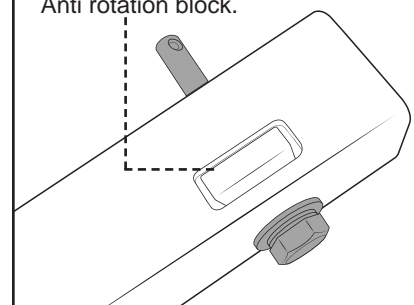



# Rhino-Rack 2 Hitch Bike RBC045

**3** Pull the top lever to disengage the lock holding the bike cradles in place. Lift the cradles up to their correct position. Release the lever and cradles will fix in place.

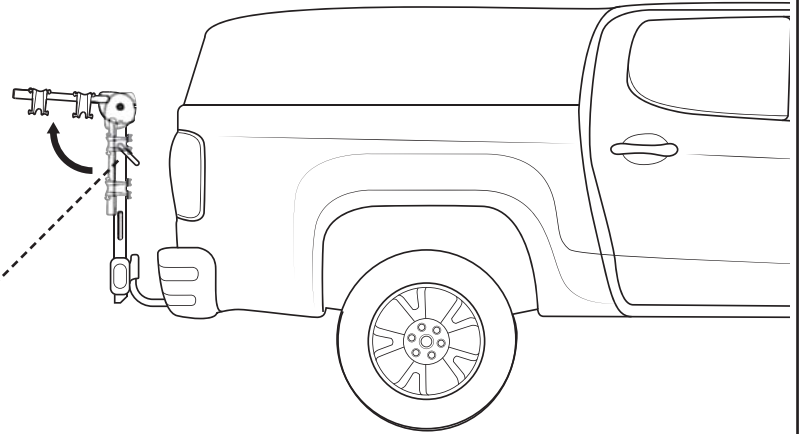
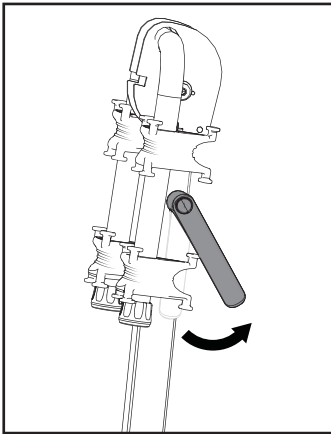

**4** Place the Bike onto the Bike Carrier. The Frame of the Bike will fit into the Cradle on the Bike Barrier as shown.

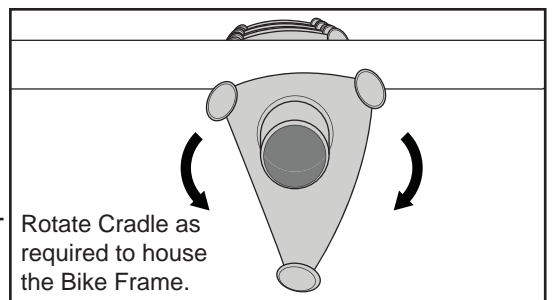
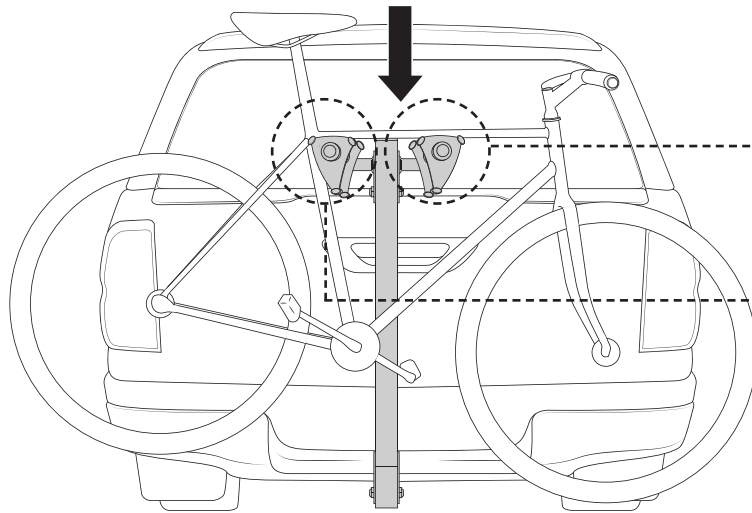

Rotate Cradle as required to house the Bike Frame.

The rear of the Bike should be secured here.

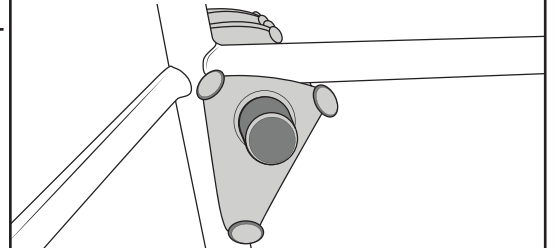

## Note

Top View: For additional Bikes (2 max), face Bike in alternate directions. This will ensure the Bikes will not clash together during travel. Ensure there is no obstruction of view to lamps and registration plates, adjust fork positions to achieve this if required.

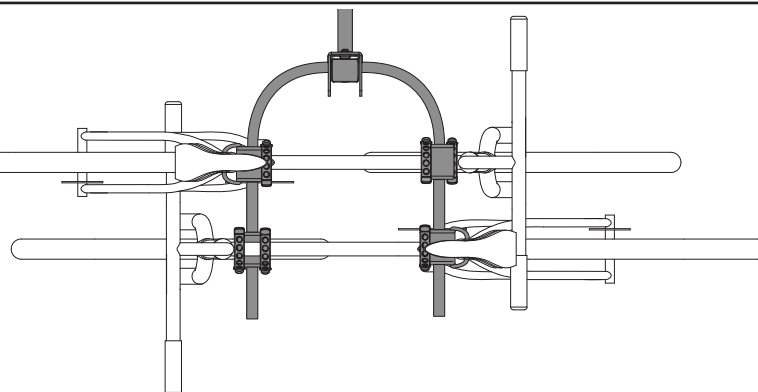

- = 1x 15kg (33lbs) MAX
- = 1x 15kg (33lbs) MAX

**5** Using the Rubber Straps on the Carrier, Fix the rear of the Frame in place.

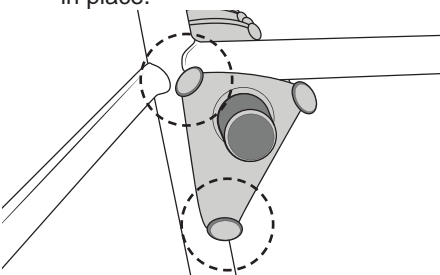

Loop a Strap over the top of the Frame and secure in place.

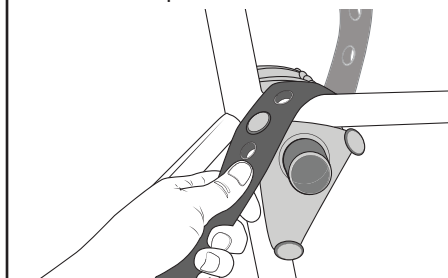

Loop a Strap around the rear of the Frame and secure as shown.

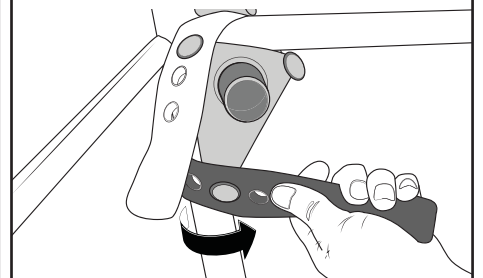



# Rhino-Rack 2 Hitch Bike RBC045 or

**6** Using the Rubber Straps on the Carrier, Fix the front of the Frame in place. Note that the front cradle only requires one rubber strap.

Select either fixture point to attach rubber strap.

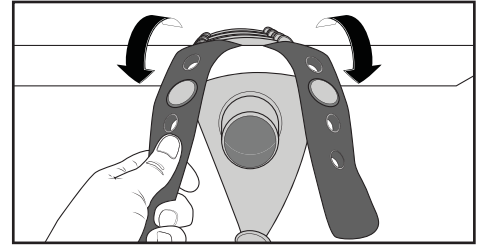
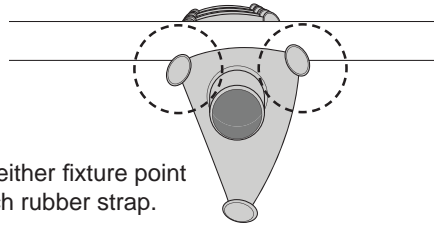

**7** Fix the bikes in place using the Strap provided. Wrap the Strap through both wheels of the bike and down to a Tow Point on the vehicle (Tow Ball or Hitch). This will provide additional safety in the event of a failure.  
**Note: Check all fixtures are secure before use.**

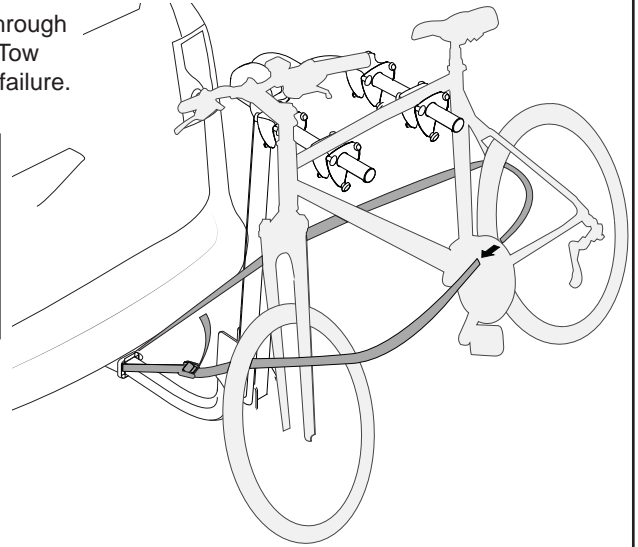
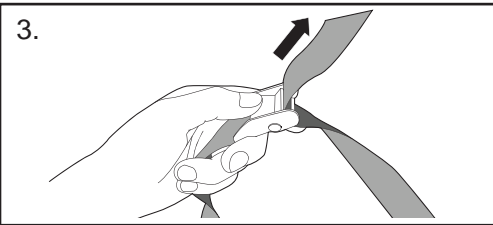
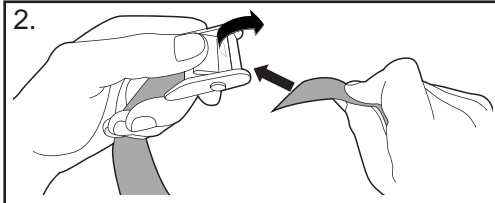
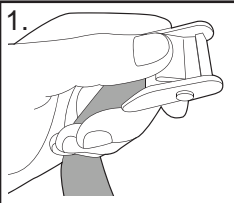

**8** When the Carrier is not in use, Lift the Locking Cam on top of the Bike Carrier. This will unlock the Carrier Arms. Drop the Arms, there will be an audible 'click' when the Arms reach their intended position.

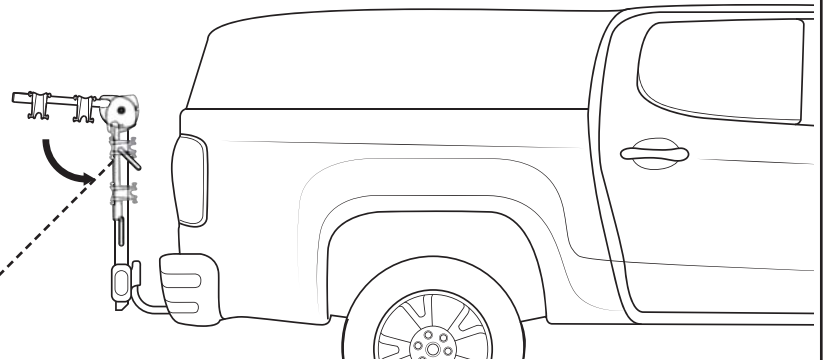
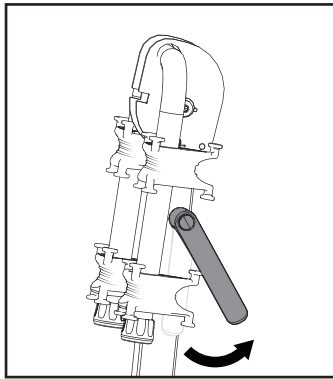

**9** To avoid collision with the rear hatch or door of the vehicle, Lift the Locking Cam at the bottom of the Bike Carrier. The unit will drop 45 degrees allowing access to the vehicle. Return to an upright position before driving.

**Note: Carrier may interfere with reverse sensors (dependent on their position), giving a false reading. The visibility of surroundings through reverse cameras may also be impacted. Be cautious when reversing. Bikes should be removed when raising and lowering carrier.**

Ensure the locking latch is secure in place before driving.

