

2360 Boswell Road
Chula Vista, CA 91914
Phone 619.216.1444
Fax 619.216.1474
E-Mail tech@explorerprocomp.com



PRO COMP SUSPENSION

Suspension Systems that Work!

Attention: It is imperative that you use only the specified PRO COMP shocks with these hoops. If any other shock other than PRO COMP are used, it may cause premature failure of the factory and/or pro comp suspension parts. It will also void any and all warranties. Suspension component failure may result in injury or death.

**Multi Shock Hoop Kit - PN
51211
2001 - 2009 Chevrolet / GMC
4 X 4
HD / 3/4 ton**

This document contains very important information that includes warranty information and instructions for resolving problems you may encounter. Please keep it in the vehicle as a permanent record.

This kit is for installation on vehicles equipped with Pro Comp suspension lift kits ONLY! It will NOT work on stock vehicles or vehicles with modifications not specific to Pro Comp Suspension.

PART LIST:

Part #	Description	Quantity	Illustration
91-2231	SHOCK HOOP	2	2
91-1574	LOWER SHOCK MOUNT	2	1
91-5307	DRIVERS SIDE HOOP BRACE	1	3
91-5309	PASSENGER SIDE HOOP BRACE	1	3
90-6199	PARTS PACK:	1	-
70-564001800	9/16" X 4" GR. 8 HEX BOLT	4	2
72-05600100816	9/16" STOVER NUT	4	2
73-05600034	9/16" HARDENED FLAT WASHER	8	2
70-0372501800	3/8" X 2 1/2" GR. 8 HEX BOLT	8	1
70-0372501800	3/8" X 1" GR. 8 HEX BOLT	4	-
70-0373001800	3/8" X 3" GR. 8 HEX BOLT	4	1
72-03700100816	3/8" STOVER NUT	8	1
73-03700034	3/8" HARDENED FLAT WASHER	16	1
70-0507001800	1/2" X 7" GR. 8 HEX BOLT	2	3
70-0505251800	1/2" X 5 1/4" GR. 8 HEX BOLT	2	4
72-05000100816	1/2" STOVER NUT	4	3,4
73-05000034	1/2" HARDENED GR. 8 FLAT WASHER	8	3,4
72-06200100548	5/8" STAKE NUT	2	3
90-6187	PARTS PACK:	1	-
54314	SHOCK SLEEVES	8	-
10999	ZIP TIES	8	-
90-6029	BRAKELINE SUPPORT KIT	1	-
90-5395	DRILL TEMPLATE	4	
90-5363	HOOP BRACE SPACER	4	
90-6667	HARDWARE PACK	1	-
70-0373001800	3/8" X 1 1/2" GR. 8 HEX BOLT	6	
72-03700100816	3/8" STOVER NUT GR. C	6	
73-03700830	3/8" SAE WASHER PLATED	12	

Optional Equipment Available from your **Pro Comp** Distributor!

PRO COMP SHOCKS ARE REQUIRED FOR THIS INSTALLATION.

(4) PN 120500

(4) PN 320500

(4) PN 920500

(4) PN MX6088

(4) PN MX6064R

(4) PN EXP3906

(1 Box) PN FX6505

(1 Box) PN FX6302

ES 1000 Series Shocks

ES 3000 Series Shocks

ES 9000 Series Shocks

MX-6 Series Shocks

MX Reservoir Shocks

Reservoir Shocks

-2- Fox Reservoir Shocks

Fox Emulsion Shocks

- ◆ This installation requires a professional mechanic!
- ◆ We recommend that you have access to a factory service manual for your vehicle to assist in the disassembly and reassembly of your vehicle. It contains a wealth of detailed information.
- ◆ Prior to installation, carefully inspect the vehicle's steering and driveline systems paying close attention to the tie rod ends, ball joints, wheel bearing preload, pitman and idler arm. Additionally, check steering-to-frame and suspension-to-frame attaching points for stress cracks. The overall vehicle must be in excellent working condition. Repair or replace all worn or damaged parts!
- ◆ Read the instructions carefully and study the illustrations before attempting installation! You may save yourself a lot of extra work.
- ◆ Check the parts and hardware against the parts list to assure that your kit is complete.
- ◆ Secure and properly block vehicle prior to beginning installation.
- ◆ ALWAYS wear safety glasses when using power tools or working under the vehicle!
- ◆ Use caution when cutting is required under the vehicle. The factory undercoating is flammable. Take appropriate precautions. Have a fire extinguisher close at hand.
- ◆ Foot pound torque readings are listed on the Torque Specifications chart on page 7. These are to be used unless specifically directed otherwise.

Disassembly with previously installed lift kit:

1. Ensure that your work space is of adequate size and the work surface is level. Place the vehicle in neutral. Place your floor jack under the front cross member and raise the vehicle high enough to place jack stands under the frame rails behind the front wheel wells. Lower the frame onto the stands. Remove the jack and place the vehicle back in gear. Set the emergency brake. Place blocks both in front of and behind each rear wheel.
2. Remove the front wheels for access to the front suspension assembly.
3. Complete installation on one side of the vehicle before moving to the other side.
4. Using your floor jack, carefully place it under the lower A-arm on the side you are working on and lift the A-arm up to remove any tension from the upper A-arm droop stop.
5. Remove the retainer nut from the upper mount of the OEM shock absorber. Keep the Grade 8 washers for reuse. Pull the shock absorber down slightly to ease the installation of the shock hoop brace.

Equipment Available from your Pro Comp Distributor!

MX6141R: Rear MX-6 Reservoir Shocks
90-6640B: Front Inner Fender Relocation Bracket Kit
51248: Front Driveshaft Kit
920500: Steering Stabilizer Kit
72400: Traction Bars
71200: Traction Bar Mounting Kit
51100: Skid Plate Kit

Also, Check out our outstanding selection of Pro Comp tires to compliment your new installation!

Assembly Instructions

1. Locate the lower shock mount (**PN 91-1574**) onto the upper A-arm. Place the tabs on the front of the new mount against the A-arm to align the bracket properly. Mark the location of the attachment holes and drill **13/32"** holes through the A-arm. *Be sure these through holes are perpendicular to the top surface through both sides of the A-arm.* Using the **3/8"** NC bolts as indicated in **Illustration 1**, secure the shock mount plate to the A-arm. **NOTE: 3/8" X 1" bolts may be used instead with some 2007 models with open a-arms.** Torque these fasteners to 35 ft lbs. **DO NOT** over torque these fasteners as damage to the A-arm will result. See **Illustration 1**.

NOTE: If the vehicle is equipped with open style A-arms you have will to drill through the A-arm weld in droop plate.

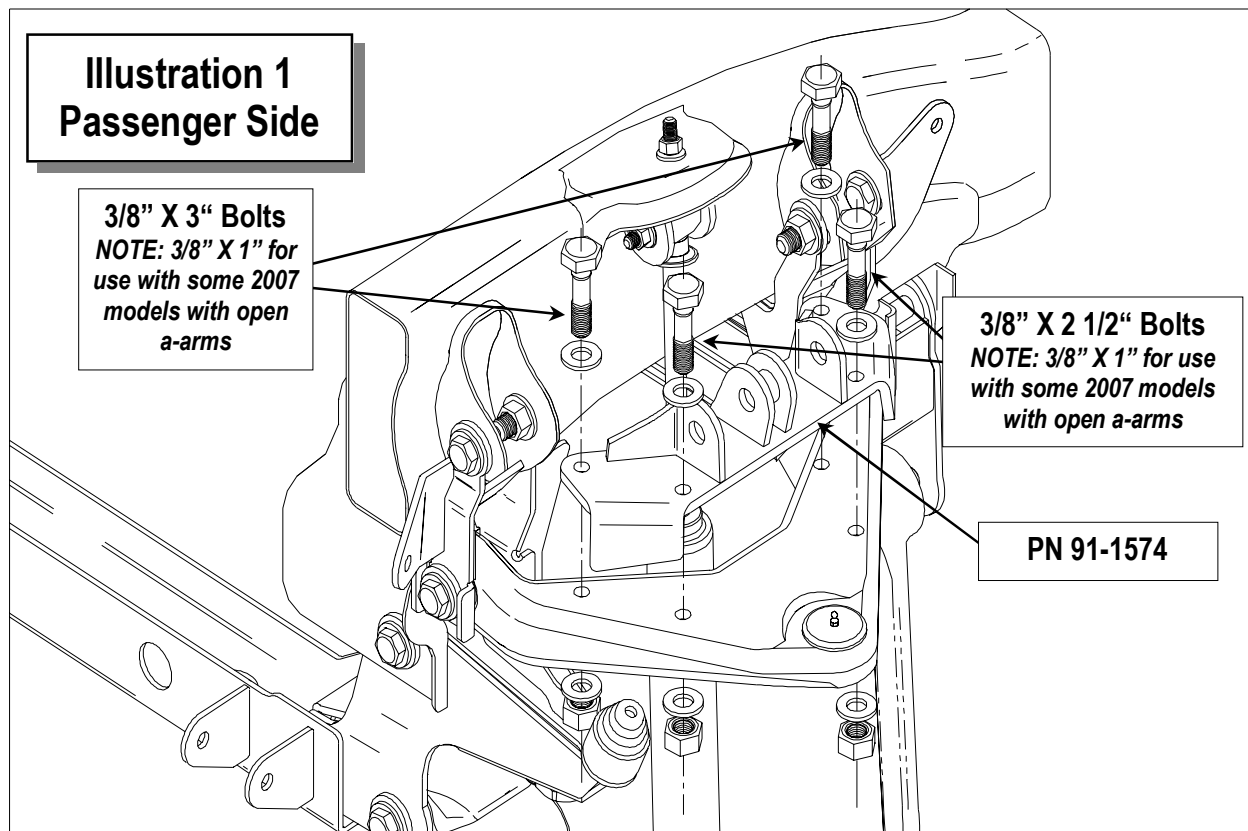

2. Remove the four **9/16"** bolts that hold the upper A-arm drops to the OEM A-arm mounts. Discard this hardware.
3. Set the hoop into the OEM upper A-arm pockets as shown in **Illustration 2**. Pay particular attention to the orientation of the shock mounts (**SEE NOTE IN ILLUSTRATION 2**). The shock mounts are oriented to the center of the vehicle. Install the supplied **9/16" NC X 4"** Grade 8 bolts through the upper A-arm drops, OEM flanges, and the hoop ends using a flat washer on each side of the flange. Install the supplied **9/16"** NC top lock nut. Snug down these bolts but leave them loose enough to allow movement for the next step. On occasion it may be necessary to "assist" the parts into place. If this is required, use only a soft face mallet to prevent damage to the finish of the hoop assembly. **Remember**, if you have to force it, there may be something physically preventing its proper installation.

NOTE: Depending on the year of the vehicle, the frame A-arm mounting pockets may need to be trimmed in order for proper installation. Carefully trim the pocket until the shock hoop mounting tabs to line up properly.

4. Install the sleeves from the shock absorber parts packs (PN 90-6187) into the shock absorber ends in preparation for the next step.
5. Drill out the small wiring clip mounting hole in the upper coil bucket using a 3/8" drill bit.
6. Install the drill template (PN 96-5395) to the under side of the upper coil bucket locating it on the large center hole and the previously drilled out 3/8" hole. Center punch the (2) remaining holes for drilling.

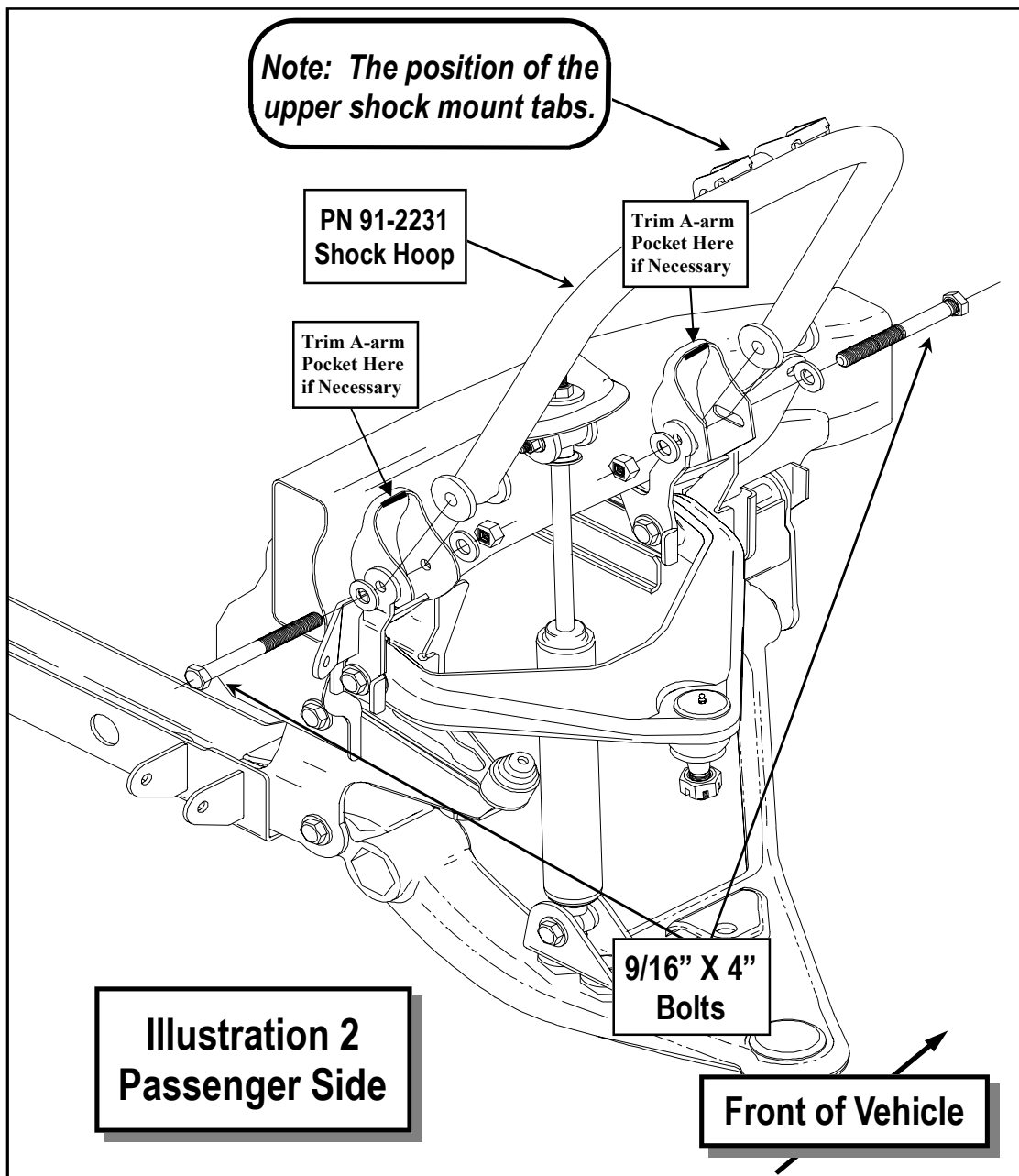

Drill the holes using a **3/8"** drill bit. See **Illustration 3**.

- Once the hoop and lower shock mount are properly mounted, swing the hoop down on its mounting pivots and install the shock brace (**PN 91-5307 Driver Side / PN 91-5309 Passenger Side**) and shocks into the shock tabs as seen in **Illustration 3** on page 6. Insert the supplied **1/2" NC X 7"** bolt through these parts using the washers and lock nut supplied. Do not tighten this hardware at this time.
- Using **Illustration 4** as a reference, swing the assembly back up and place the strut brace over the **OEM** shock mount. Pull the shock mount bolt back up through the **OEM** shock bracket and through the shock hoop brace mount hole. Re-install the previously saved flat washer and install the new **5/8" stake nut** from parts pack (**PN 90-6199**). Tighten this nut to specifications keeping the shock mount through bolts parallel to the vehicle frame. Install the **3/8" X 1 1/2"** bolts and hardware through the shock brace and the previously drilled holes in the coil bucket. Torque these bolts according to the

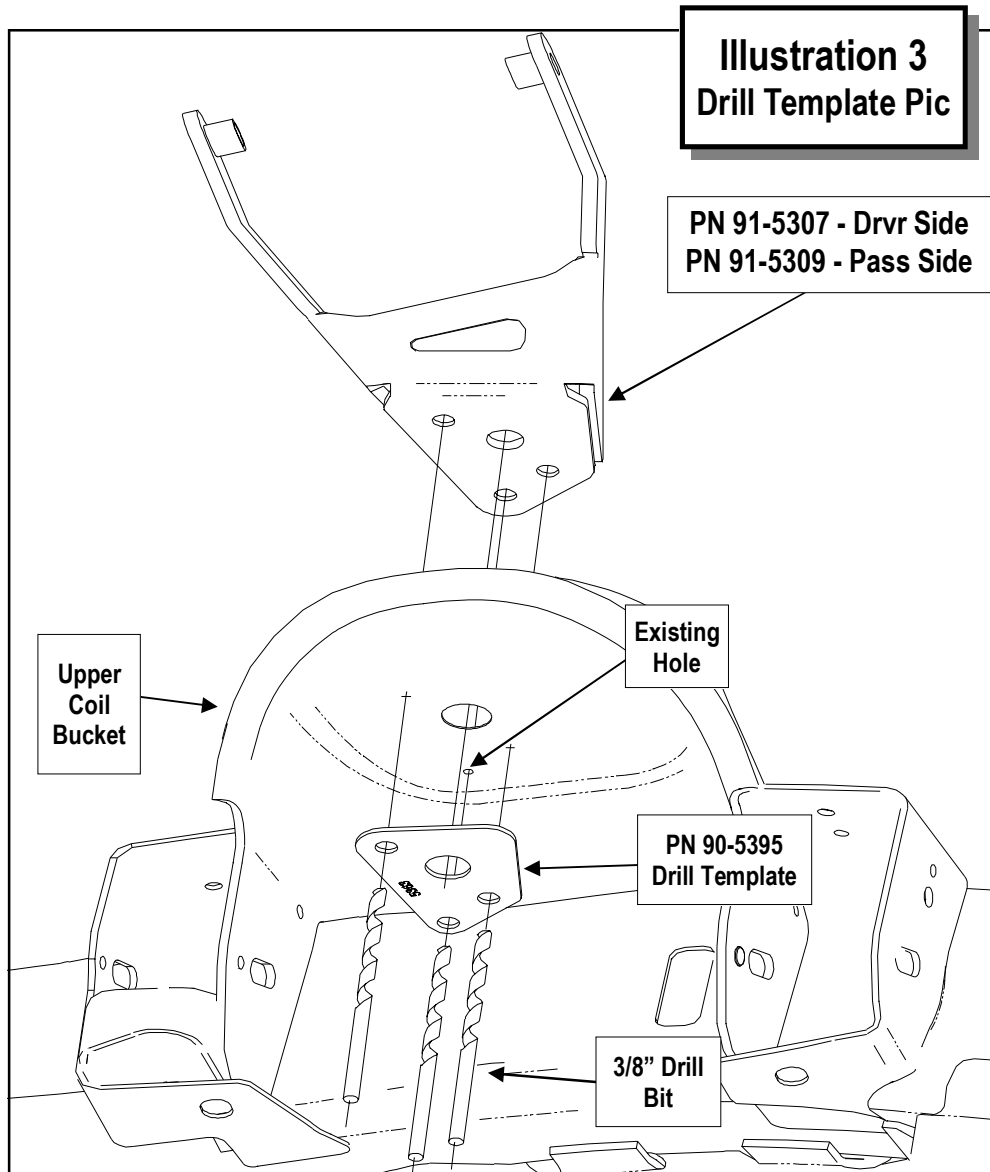

torque chart on page 10.

NOTE: Due to variations in the frame from the factory, some older models may require stacking of the hoop brace spacer (90-5363) between the upper coil buckets and the hoop braces (91-5307 drvr and 91-5309).

9. Install the shocks into the lower shock mounts using the supplied $1/2"$ X $5 1/4"$ bolts with a washer through the mount tabs and shocks. Install the supplied flat washer and nut and torque to specifications. **Illustration 5** on page 8.
10. The brake line mounting brackets will have to be drilled out to accommodate the new $3/8"$ bolt. These looms were modified in the lift kit installation. See **Illustration 6** on page 9.
11. Tighten all hardware to specifications.

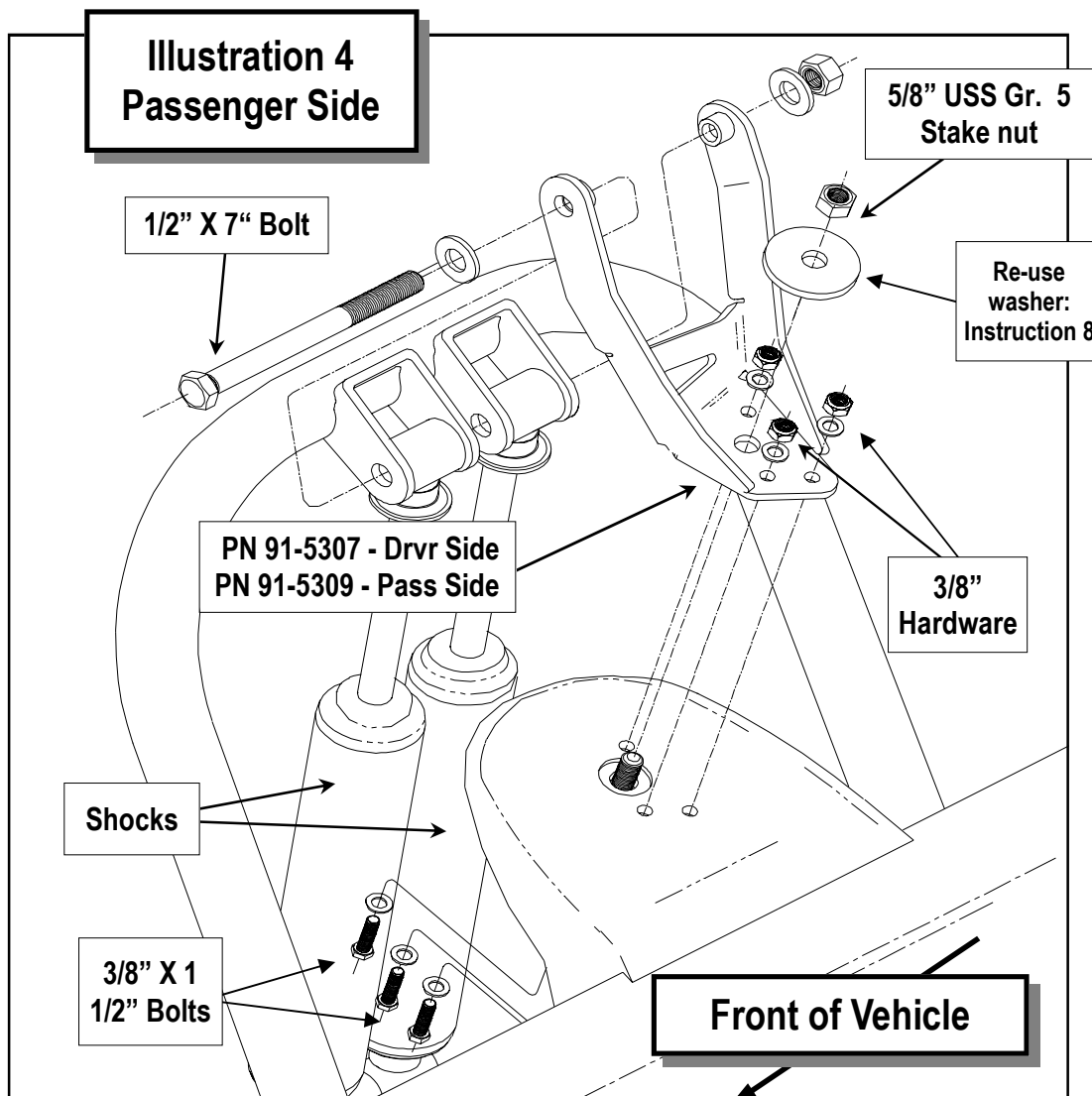

12. At this point, check the entire assembly for clearance. It is ***critical*** that brake lines and ABS wiring is secured in such a manner that there is no rubbing or scraping of these components,
13. When complete, the installation should look very similar to **Illustration 7** on **Page 9**.
14. Reinstall the wheels and tires and repeat the procedure for the opposite side of the vehicle.
15. On completion, cycle the steering full left and full right and check the entire front end for adequate clearance. Pay close attention to the brake line and ABS wiring and reroute these if needed to ensure adequate clearance. This step is ***very*** important to minimize the chance of rubbing through essential brake lines and ABS wiring. Zip ties are provided to secure these components.

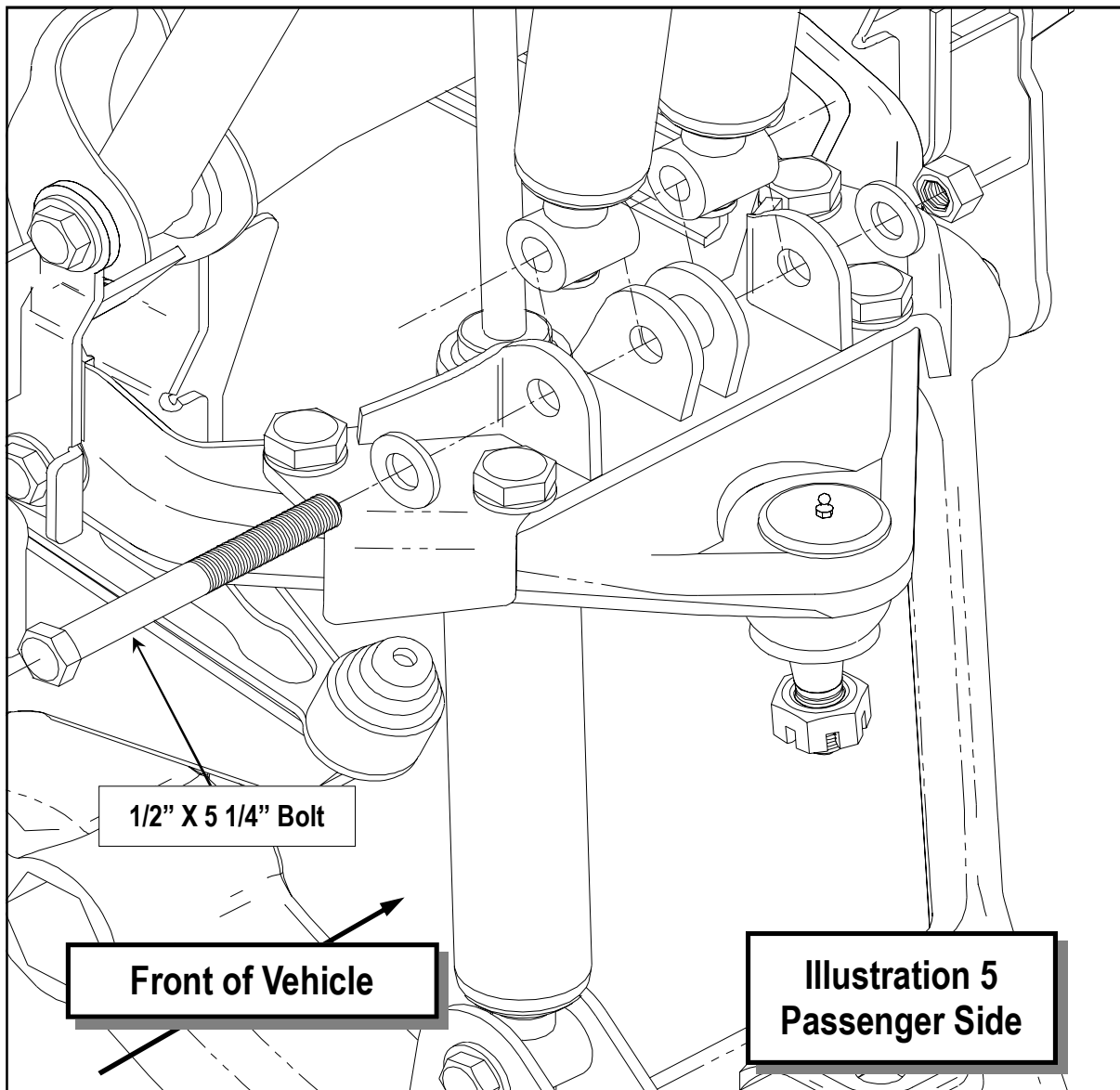

NOTES:

- ⇒ After 100 miles recheck for proper torque on all newly installed hardware.
- ⇒ Recheck all hardware for tightness after off road use.

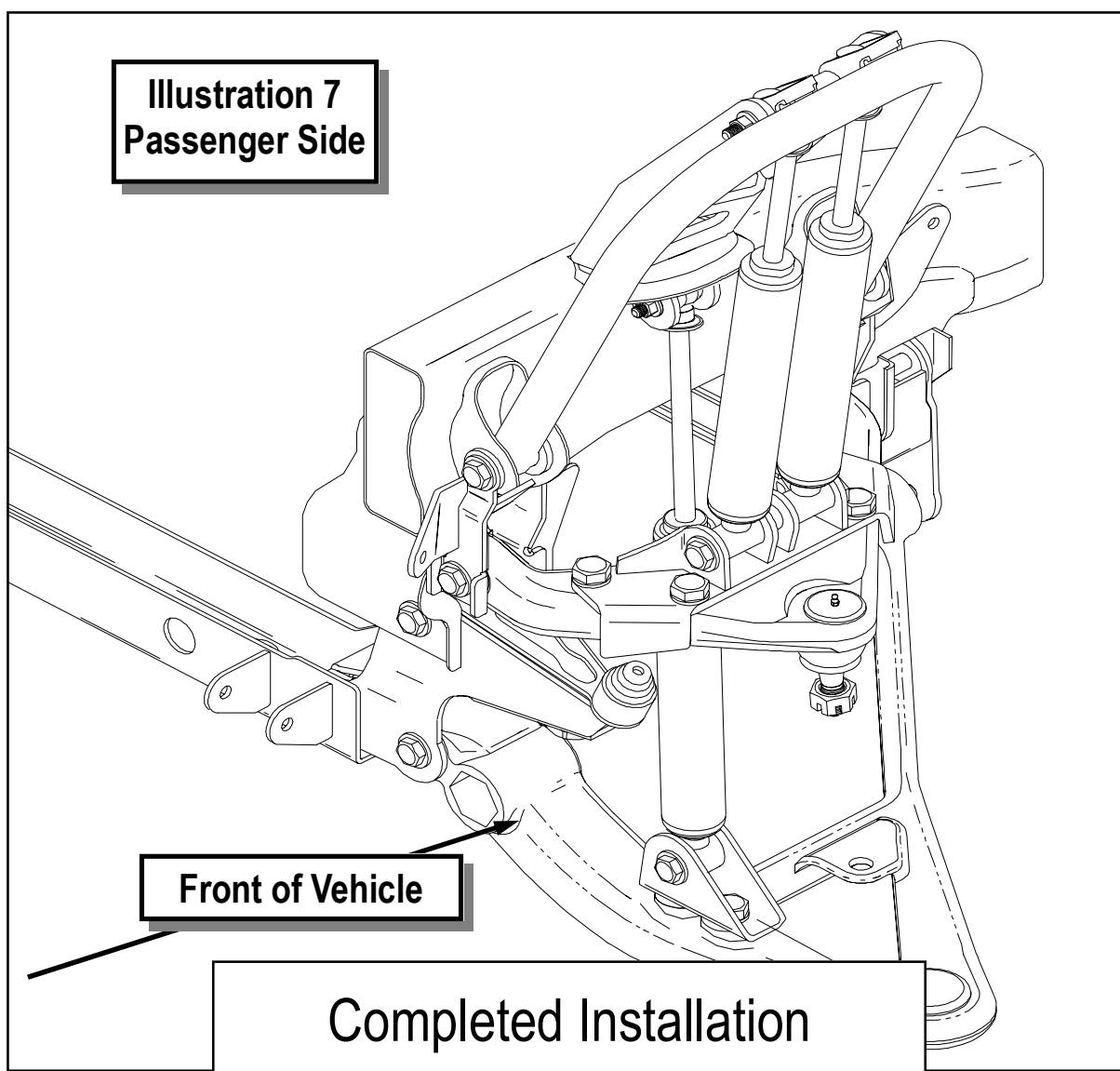
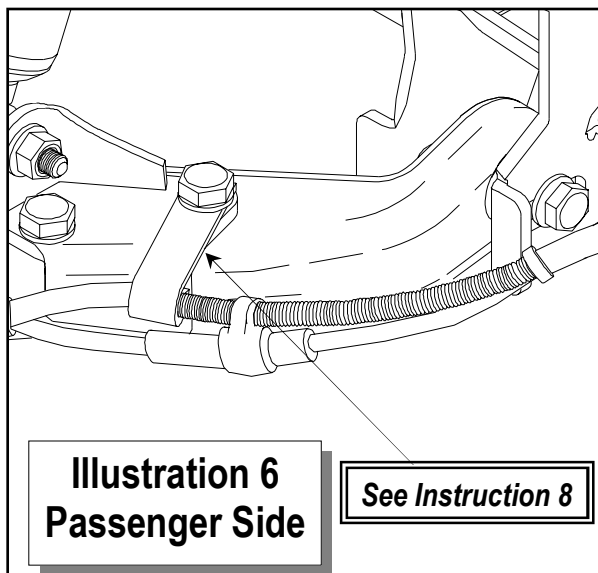

Use this only as a guide for hardware without a called out torque specification in the instruction manual.

Bolt Torque and ID						
Decimal System			Metric System			
All Torques in Ft. Lbs. Maximums						
Bolt Size	Grade 5	Grade 8	Bolt Size	Class 9.8	Class 10.9	Class 12.9
5/16	15	20	M6	5	9	12
3/8	30	45	M8	18	23	27
7/16	45	60	M10	32	45	50
1/2	65	90	M12	55	75	90
9/16	95	130	M14	85	120	145
5/8	135	175	M16	130	165	210
3/4	185	280	M18	170	240	290

1/2-13x1.75 HHCS **Grade 5 Grade 8**
(No. of Marks + 2)

D T L X

G = Grade (Bolt Strength)
D = Nominal Diameter (Inches)
T = Thread Count (Threads per Inch)
L = Length (Inches)
X = Description (Hex Head Cap Screw)

M12-1.25x50 HHCS

D T L X

P = Property Class (Bolt Strength)
D = Nominal Diameter (Millimeters)
T = Thread Pitch (Thread Width, mm)
L = Length (Millimeters)
X = Description (Hex Head Cap Screw)

Notice to Owner operator, Dealer and Installer:

Vehicles that have been enhanced for off-road performance often have unique handling characteristics due to the higher center of gravity and larger tires. This vehicle may handle, react and stop differently than many passenger cars or unmodified vehicles, both on and off-road. You must drive your vehicle safely! Extreme care should always be taken to prevent vehicle rollover or loss of control, which can result in serious injury or even death. Always avoid sudden sharp turns or abrupt maneuvers and allow more time and distance for braking! Pro Comp reminds you to fasten your seat belts at all times and reduce speed! We will gladly answer any questions concerning the design, function, maintenance and correct use of our products.

Please make sure your Dealer/Installer explains and delivers all warning notices, warranty forms and instruction sheets included with Pro Comp product.

Application listings in this catalog have been carefully fit checked for each model and year denoted. However, Pro Comp reserves the right to update as necessary, without notice, and will not be held responsible for misprints, changes or variations made by vehicle manufacturers. Please call when in question regarding new model year, vehicles not listed by specific body or chassis styles or vehicles not originally distributed in the USA.

Please note that certain mechanical aspects of any suspension lift product may accelerate ordinary wear of original equipment components. Further, installation of certain Pro Comp products may void the vehicle's factory warranty as it pertains to certain covered parts; it is the consumer's responsibility to check with their local dealer for warranty coverage before installation of the lift.

Warranty and Return policy:

Pro Comp warrants its full line of products to be free from defects in workmanship and materials. Pro Comp's obligation under this warranty is limited to repair or replacement, at Pro Comp's option, of the defective product. Any and all costs of removal, installation, freight or incidental or consequential damages are expressly excluded from this warranty. Pro Comp is not responsible for damages and / or warranty of other vehicle parts related or non-related to the installation of Pro Comp product. A consumer who makes the decision to modify his vehicle with aftermarket components of any kind will assume all risk and responsibility for potential damages incurred as a result of their chosen modifications. Warranty coverage does not include consumer opinions regarding ride comfort, fitment and design. Warranty claims can be made directly with Pro Comp or at any factory authorized Pro Comp dealer.

IMPORTANT! To validate the warranty on this purchase please be sure to mail in the warranty card.

Claims not covered under warranty-

- Parts subject to normal wear, this includes bushings, bump stops, ball joints, tie rod ends and heim joints
 - Discontinued products at Pro Comp's discretion
- Bent or dented product
- Finish after 90 days
- Leaf or coil springs used without proper bump stops
- Light bulbs
- Products with evident damage caused by abrasion or contact with other items
- Damage caused as a result of not following recommendations or requirements called out in the installation manuals
- Products used in applications other than listed in Pro Comp's catalog
- Components or accessories used in conjunction with other manufacturer's systems
- Tire & Wheel Warranty as per Pro Competition Tire Company policy
- Warranty claims without "Proof of Purchase"
- Pro Comp Pro Runner coil over shocks are considered a serviceable shock with a one-year warranty against leakage only. Rebuild service and replacement parts will be available and sold separately by Pro Comp. Contact Pro Comp for specific service charges.
- Pro Comp accepts no responsibility for any altered product, improper installation, lack of or improper maintenance, or improper use of our products.

E-Mail: tech@explorerprocomp.com
Website: www.explorerprocomp.com
Fax: (619) 216-1474
Ph: (619) 216-1444

PLACE
WARRANTY REGISTRATION
NUMBER
HERE: _____