

400 W. Artesia Blvd.  
Compton, CA 90220  
Fax: (310) 747-3912  
Ph: 1-800-776-0767  
E-Mail: info@procompusa.com  
Website: www.procompusa.com

Latest Revision  
11.2.13



off-road driven!™

## PRO COMP SUSPENSION

---

***IMPORTANT!: DO NOT install this kit on 2WD vehicles.***

**Part # K1144B/K1144BMX  
51017B/51017BMX  
6" Lift  
2007 –2013 Chevrolet  
Silverado 4WD Kit  
With Front Driveshaft**

This document contains very important information that includes warranty information and instructions for resolving problems you may encounter. Please keep it in the vehicle as a permanent record.

## Box 1 of 7-PN 51017B-1

Part #	Description	Qty.	Illus.	Page
<b>90-6299</b>	<b>HARDWARE PACK: Rear Brake Line</b>	<b>1</b>	-	-
70-0311001500	5/16" X 1" GR.5 HEX BOLT	2	-	-
72-03100100512	5/16" NYLOCK NUT	2	-	-
73-03100030	5/16" SAE FLAT WASHER	4	-	-
<b>90-3341</b>	<b>REAR AXLE BRAKE LINE RELOCATION BRACKET</b>	<b>1</b>	-	-
<b>95-400</b>	<b>CAST IRON LIFT BLOCK</b>	<b>2</b>	<b>17</b>	<b>17</b>
<b>13-90087</b>	<b>9/16" U-BOLT</b>	<b>4</b>	<b>17</b>	<b>17</b>
<b>20-65302</b>	<b>HARDWARE PACK: U-Bolts</b>	<b>1</b>	-	-
13-30330	9/16" FLAT WASHER	8	17	17
13-10423	9/16" HIGHNUT	8	17	17
<b>90-3694</b>	<b>DIFF MOUNT: Drvr</b>	<b>1</b>	<b>4,8</b>	<b>9,11</b>
<b>90-3697</b>	<b>DIFF MOUNT: Pass</b>	<b>1</b>	<b>5,8</b>	<b>9,11</b>
<b>90-4077</b>	<b>CV SPACER</b>	<b>2</b>	<b>11</b>	<b>12</b>
<b>90-6513</b>	<b>HARDWARE PACK: Diff Mount Drvr Crossmember</b>	<b>1</b>	-	-
70-0311001800	5/16"-18 X 1 HEX BOLT GR.	4	8	11
72-031100816	5/16"-18 NYLOCK NUT .	4	8	11
73-04300034	5/16" SAE FLAT WASHER GR. 8	8	8	11
<b>90-6514</b>	<b>HARDWARE PACK: Diff Mount Drvr</b>	<b>1</b>	-	-
70-0501751800	1/2"-13 X 1 3/4" HEX BOLT GR. 8	2	6	10
72-050100816	1/2"-13 STOVER NUT	2	6	10
73-05000034	1/2" SAE FLAT WASHER GR. 8	4	6	10
<b>90-6251</b>	<b>HARDWARE PACK: Differential</b>	<b>1</b>	-	-
70-0564001800	9/16"-12 X 4" HEX BOLT GR. 8	1	8	11
70-0561751800	9/16"-12 X 1 3/4" HEX BOLT GR. 8	2	6	10
72-056100816	9/16"-12 STOVER NUT	3	6,8	10,11
73-05600034	9/16" SAE FLAT WASHER GR. 8	4	6,8	10,1
73-05600034	9/16" HARDENED FLAT WASHER	2	6,8	10,11
70-0563001800	7/16"-14 X 3" HEX BOLT GR. 8	1	3	8
72-056100816	7/16"-14 STOVER NUT	1	3	8
73-05600034	7/16" SAE FLAT WASHER GR. 8	2	3	8
71-100601251000	M10-1.5 X 60 HEX BOLT GR. 10.9	16	3	8
73-01008840	M10 USS FLAT WASHER	16	3	8
<b>90-3957</b>	<b>5/16" REAR SPRING SPACER</b>	<b>4</b>	<b>17</b>	<b>17</b>

## Box 2 of 7-PN 51007B-2

<b>90-4491</b>	<b>KNUCKLE: Drvr</b>	<b>1</b>	-	-
<b>90-4492</b>	<b>KNUCKLE: Pass</b>	<b>1</b>	-	-
<b>90-6522</b>	<b>HARDWARE PACK: Adel Clamps</b>	<b>2</b>	-	-
<b>90-3240</b>	<b>ADEL CLAMP</b>	<b>2</b>	<b>14</b>	<b>14</b>
<b>90-6556</b>	<b>HARDWARE PACK: CV Knuckle Spacer Ring</b>	<b>1</b>	-	-
<b>90-3809</b>	<b>CV KNUCKLE SPACER RING</b>	<b>2</b>	-	-
<b>90-6709</b>	<b>HARDWARE PACK: Spare Tire Wheel Spacer</b>	<b>1</b>	-	-
<b>90-3950</b>	<b>SPARE TIRE WHEEL SPACER</b>	<b>2</b>	-	-
<b>90-6439</b>	<b>HARDWARE PACK: Tie Rod Jam Nut</b>	<b>1</b>	-	-
.160FNFJZ	16mm-1.5 HEX JAM NUT	2	-	-

Part #	Description	Qty.	Illus.	Page
90-3688	REAR CROSSMEMBER	1	9	12
90-2319	COMPRESSION STRUTS	2	16	15
90-6234	<b>HARDWARE PACK: Compression Strut</b>	1	-	-
70-0501251800	1/2" X 1 1/4" GR. 8 HEX BOLT	2	16	15
70-0504001800	1/2" X 4" GR. 8 HEX BOLT	4	16	15
72-050100816	1/2" GR. 8 STOVER NUT	4	16	15
73-05000034	1/2" SAE HARDENED FLAT WASHER	1	16	15
90-3353	COMPRESSION STRUT NUT PLATE	2	16	15
90-1104	COMPRESSION STRUT MOUNT	2	16	15
90-6263	<b>HARDWARE PACK: Compression Struts</b>	1	-	-
15-11148	COMPRESSION STRUT BUSHING	8	16	15
90-2109	SLEEVE, COMPRESSION STRUT	4	16	15

Box 4 of 7-PN 51007B-4

90-3684	FRONT CROSSMEMBER	1	7	1 0
90-6284	<b>HARDWARE PACK: Crossmember</b>	1	-	-
70-0624501800	5/8"-11 x 4 1/2" HEX BOLT GR. 8	2	10	12
70-0625501800	5/8"-11 X 5 1/2" BOLT GR. 8	2	10	12
72-06200100512	5/8"-11 STOVER NUT	4	10	12
73-06200030	5/8" SAE FLAT WASHER	8	10	12
90-6498	<b>HARDWARE PACK: Sway Bar Drop</b>	1	-	-
71-100301251000	10mm-1.5 X 30mm 10.9 HEX BOLT	4	15	14
73-01010930	10mm 10.9 FLAT WASHER	4	15	14
70-0432501800	7/16"-14 X 2 1/2" GR. 8 HEX BOLT	4	15	14
72-043100816	7/16"-14 STOVER NUT	4	15	14
73-04300034	7/16" SAE FLAT WASHER	8	15	14
90-3632	SWAY BAR DROP- Drvr	1	15	14
90-3635	SWAY BAR DROP- Pass	1	-	-
90-7734	FRONT BRAKE LINE DROP BRACKET- Drvr	1		
90-7735	FRONT BRAKE LINE DROP BRACKET- Pass	1		
90-6517	<b>HARDWARE PACK: Brake Line Bracket</b>	1	-	-
70-0313751800	5/16" X 1" GR. 8 HEX BOLT	2	15	14
73-03100830	5/16" FLAT WASHER	4	15	14
72-031100816	5/16" GR. 8 STOVER NUT	2	15	14
70-0251001800	1/4" X 1.0" GR. 8 HEX BOLT	4	15	14
73-02500830	1/4" FLAT WASHER	8	15	14
72-025100816	1/4" GR. 8 NYLOCK NUT	4	15	14
-Not used-	#10-24 X 3/4" PHILLIPS MACHINE SCREW	4	15	14
-Not used-	#10-24 PLATED NYLOCK WASHER	4	15	14
-Not used-	#10 WASHERS	8	15	14
-Not used-	#8 X 3/4" HEX BOLT (w/ loose "fender" washer on bolt)	8	15	14
90-6515	<b>HARDWARE PACK: Front Differential Support Bracket</b>	1	-	-

Part #	Description	Qty.	Illus.	Page
15-11148	BUSHING, DIFFERENTIAL MOUNT	2	3	8
90-2108	SLEEVE, DIFFERENTIAL MOUNT-2.39"	1	3	8
<b>90-6516</b>	<b>HARDWARE PACK: Front Diff Mount Tabs</b>	<b>1</b>	-	-
90-3691	FRONT DIFFERENTIAL MOUNT TABS	2	8	11
<b>90-3692</b>	<b>FRONT DIFFERENTIAL SUPPORT BRACKET</b>	<b>1</b>	<b>3</b>	<b>8</b>
<b>90-6872</b>	<b>HARDWARE PACK: ABS Bracket</b>	<b>1</b>	-	-
<b>90-7876</b>	<b>ABS LINE RELOCATION BRACKET</b>	<b>2</b>	<b>14</b>	<b>14</b>
72-025100512	1/4" SAE FLAT WASHER	4	14	14
72-025100512	1/4" NYLOCK NUT	4	14	14
<b>Box 5 of 7-PN 51099B-5</b>				
<b>13127-1</b>	<b>ADD-A-LEAF</b>	<b>2</b>	<b>17</b>	<b>17</b>
<b>90-3825</b>	<b>HARDWARE PACK: Add-a-leaf</b>	<b>1</b>	-	-
97-380	3/8" X 4 1/2" CENTER BOLT	2	17	17
8337-1	3/8" CENTER BOLT LOCK NUT	2	17	17
98-00250-1	2 1/2" SPRING CLAMP	4	17	17
98-00250-2	2 1/2" SPRING PLATE	4	17	17
<b>Box 6 of 7-PN 51007B-6</b>				
<b>928001</b>	<b>ES 9000 SHOCK</b>	<b>2</b>	-	-
<b>91-8284</b>	<b>STRUT SPACER</b>	<b>2</b>	<b>13</b>	<b>13</b>
<b>90-6317</b>	<b>HARDWARE PACK: Spacer Mount</b>	<b>1</b>	-	-
72-043200810	7/16-20 GR. 8 PLATED HEX NUT	6	13	13
73-04300830	7/16 SAE FLATWASHER ZINC	6	13	13
73-04300836	7/16 SPLIT LOCK WASHER	6	13	13
<b>Or Box 6 of 8-PN 51007BMX-6</b>				
<b>624000</b>	<b>COIL OVER</b>	<b>1</b>	<b>12,13</b>	<b>13</b>
<b>90-6327</b>	<b>HARDWARE PACK: Spacer Mount</b>	<b>1</b>	-	-
72-0432501800	7/16" X 2 1/2" GR. 8 HEX BOLT	2	12	13
73-04300830	7/16" SAE FLATWASHER ZINC	4	12	13
73-04300816	7/16" STOVER NUT	2	12	13
<b>90-6492</b>	<b>HARDWARE PACK: Coil over mounting spacers</b>	<b>1</b>	-	-
90-2433	UPPER SPACERS: -10 Mono Ball Spacer	4	12,13	13
<b>90-3712</b>	<b>COIL OVER MOUNT: Upper Bracket</b>	<b>1</b>	<b>12,13</b>	<b>13</b>
<b>90-6317</b>	<b>HARDWARE PACK: Spacer Mount</b>	<b>1</b>	-	-
72-043200810	7/16-20 GR. 8 PLATED HEX NUT	6	12	13
73-04300830	7/16 SAE FLATWASHER ZINC	6	12	13
73-04300836	7/16 SPLIT LOCK WASHER	6	12	13
<b>MX6098</b>	<b>MX6 SHOCKS</b>	<b>1</b>	-	-
<b>90-6587</b>	<b>HARDWARE PACK: Coil Over Spacer</b>	<b>1</b>	-	-
<b>90-3956</b>	<b>1/4" Spacer</b>	<b>2</b>	<b>12</b>	<b>13</b>

Part #	Description	Qty.	Illus.	Page
624000	COIL OVER	1	12	13
90-6327	<b>HARDWARE PACK: Spacer Mount</b>	1	-	-
72-0432501800	7/16" X 2 1/2" GR. 8 HEX BOLT	2	12	13
73-04300830	7/16" SAE FLATWASHER ZINC	4	12	13
73-04300816	7/16" STOVER NUT	2	12	13
90-3010	COIL OVER WRENCH LARGE	1	-	-
90-3011	COIL OVER WRENCH SMALL	1	-	-
90-6318	<b>HARDWARE PACK: Coil Over Mount</b>	1	-	-
70-0502751800	1/2"-13 X 2 3/4" BOLT	2	12	13
73-05000830	1/2" SAE FLATWASHER ZINC	4	12	13
72-050100816	1/2-13 UNITORQUE NUT GR. C Z	2	12	13
90-3712	COIL OVER MOUNT: Upper Bracket	1	12	13
MX6098	MX6 SHOCKS	1	-	-
<b>Box- PN 51246</b>				
90-4051	DRIVESHAFT	1	-	-

## Important!

- On some vehicles the driver's side OE chassis wire harness that connects to the ABS wire may be shorter, from the factory, than others. If the line needs to be extended GM #19149296 (ACD#PT2232) can be installed into the chassis wire harness.
  - Front end and head light realignment is necessary!
  - Speedometer and ABS recalibration will be necessary if larger tires (10% more than stock diameter) are installed.
- ⇒ Due to differences in manufacturing, dimensions and inflated measurements, tire and wheel combinations should be test fit prior to installation. Tire and wheel choice is crucial in assuring proper fit, performance, and the safety of your Pro Comp equipped vehicle. For this application, we recommend a 17" or larger wheel not to exceed 8" in width with a maximum backspacing of 4.5" must be used. Additionally, a quality tire of radial design, not exceeding 35" tall X 12.5" wide is also recommended. Please note that the use of a 35" X 12.5" tire may require modification to the front valance. Violation of these recommendations will not be endorsed as acceptable by Pro Comp Suspension and will void any and all warranties either written or implied.
- ⇒ 2007 trucks require a 17" wheels to clear the calipers.

## Before You Begin:

- ⇒ Read the instructions and study the illustrations before attempting the installation.
- ⇒ Separating the parts according to the areas where they will be used and placing the hardware with the brackets before you begin will save installation time.
- ⇒ Check the parts and hardware against the parts list to assure that your kit is complete.
- ⇒ ALWAYS wear safety glasses when using power tools or working beneath your vehicle.
- ⇒ Always use NEW cotter pins on re-assembly! (These items are NOT supplied)

# Introduction:

- ◆ This installation requires a professional mechanic!
- ◆ We recommend that you have access to a factory service manual for your vehicle to assist in the disassembly and reassembly of your vehicle. It contains a wealth of detailed information.
- ◆ Ensure that your work space is of adequate size and the work surface is level. Place the vehicle in neutral. Place your floor jack under the front cross member and raise vehicle. Place jack stands under the frame rails behind the front wheel wells and lower the frame onto the stands. Remove the jack and place the vehicle back in gear, set the emergency brake, and place blocks both in front and behind the rear wheels.
- ◆ Prior to installation, carefully inspect the vehicle's steering and driveline systems paying close attention to the tie rod ends, ball joints, wheel bearing preload, pitman and idler arm. Additionally, check steering-to-frame and suspension-to-frame attaching points for stress cracks. The overall vehicle must be in excellent working condition. Repair or replace all worn or damaged parts!
- ◆ Read the instructions carefully and study the illustrations before attempting installation! You may save yourself a lot of extra work.
- ◆ Check the parts and hardware against the parts list to assure that your kit is complete. Separating parts according to the areas where they will be used and placing the hardware with the brackets before you begin will save installation time.
- ◆ Check the special equipment list and ensure the availability of these tools.
- ◆ Secure and properly block vehicle prior to beginning installation.
- ◆ ***ALWAYS*** wear safety glasses when using power tools or working under the vehicle!
- ◆ Use caution when cutting is required under the vehicle. The factory undercoating is flammable. Take appropriate precautions. Have a fire extinguisher close at hand.
- ◆ Foot pound torque readings are listed on the Torque Specifications chart at the end of the instructions. These are to be used unless specifically directed otherwise. Apply Loctite® retaining compound where specified.
- ◆ ***Please note that while every effort is made to ensure that the installation of your Pro Comp lift kit is a positive experience, variations in construction and assembly in the vehicle manufacturing process will virtually ensure that some parts may seem difficult to install. Additionally, the current trend in manufacturing of vehicles results in a frame that is highly flexible and may shift slightly on disassembly prior to installation. The use of pry bars and tapered punches for alignment is considered normal and usually does not indicate a faulty product. However, if you are uncertain about some aspect of the installation process, please feel free to call our tech support department at the number listed on the cover page. We do not recommend that you modify the Pro Comp parts in any way as this will void any warranty expressed or implied by the Pro Comp Suspension company.***

## SPECIAL EQUIPMENT

Please refer to your service manual for more information. These tool may be purchased at your local GM dealer.

1. A special removal tool is required for safe removal of the tie rods. (Tie rod puller # **J6627-A**)
2. A special removal tool is required for safe removal of the ball joints. (Ball joint separator tool # **J23742**)

You may be able to rent any of these tools at your local parts store.

### Optional Equipment Available from your Pro Comp Distributor!

51104: SKID PLATE  
51207BMX: MX-6 COIL OVER UPGRADE KIT  
51247: Driveshaft: 36.8" Long

Also, check out our outstanding selection of Pro Comp tires to compliment your new installation!

## FRONT INSTALLATION:

1. Position your vehicle on a smooth, flat, hard surface (i.e. concrete or asphalt). Block the rear tires and set the emergency brake.
2. Measure and record the distance from the center of each wheel to the top of its fender opening. Record below.

LF: \_\_\_\_\_ RF: \_\_\_\_\_

LR: \_\_\_\_\_ RR: \_\_\_\_\_

3. Place the vehicle in neutral. Place your floor jack under the front axle and raise the vehicle. Place jack stands under the frame rails and lower the frame onto the stands. Remove the jack and place the vehicle back in gear, set the emergency brake, and place blocks both in front and behind the rear wheels.
4. Remove the front wheels from the vehicle.
5. Unclip the ABS bracket from coil bucket and A-arm. Unplug the ABS connector.
6. Unbolt the ABS strap from the steering knuckle. Secure the ABS wire out of the work area. Discard the bracket.
7. Using pliers carefully open the a-arm brake line retaining bracket. Remove the rubber brake hose from the bracket. Using a cut off wheel, cut the bracket at the bend.  
**NOTE: Be very careful to not damage the rubber line in any way during it's removal from the bracket.**
8. Unbolt the brake line bracket from the upper A-arm.
9. Using the proper tool carefully separate the outer tie rod end from the knuckle.
10. Remove the brake caliper and caliper bracket assembly and the rotor. Secure them clear from the work area. **DO NOT** let the caliper hang by the brake line or damage may result.
11. Mark the orientation of the sway bar and remove it from the vehicle.
12. Unbolt and remove the sway bar end links from the vehicle.

13. Unbolt the CV axle from the differential.
14. Using the proper tool carefully separate the upper ball joint from the knuckle. Loosen but **DO NOT** remove the retaining nut from the upper ball joint.
15. Support the lower control arm with a jack and unbolt the lower strut mounting bolts from the lower control arm mount.
16. Unbolt the lower control arms retaining bolts
17. Unbolt the previously loosened upper ball joint retaining nut and remove the lower control arm, knuckle and CV axle assembly from the vehicle.
18. Remove the clips that hold the ABS wire to the upper strut mounting studs.
19. Unbolt the nuts on the upper strut mounting studs. Carefully remove the strut from the vehicle.
20. Unbolt the front driveshaft and remove it from the vehicle. Save the hardware for reuse.
21. Unplug the differential wiring harness clips and vent tube.
22. Remove the factory rear crossmember support

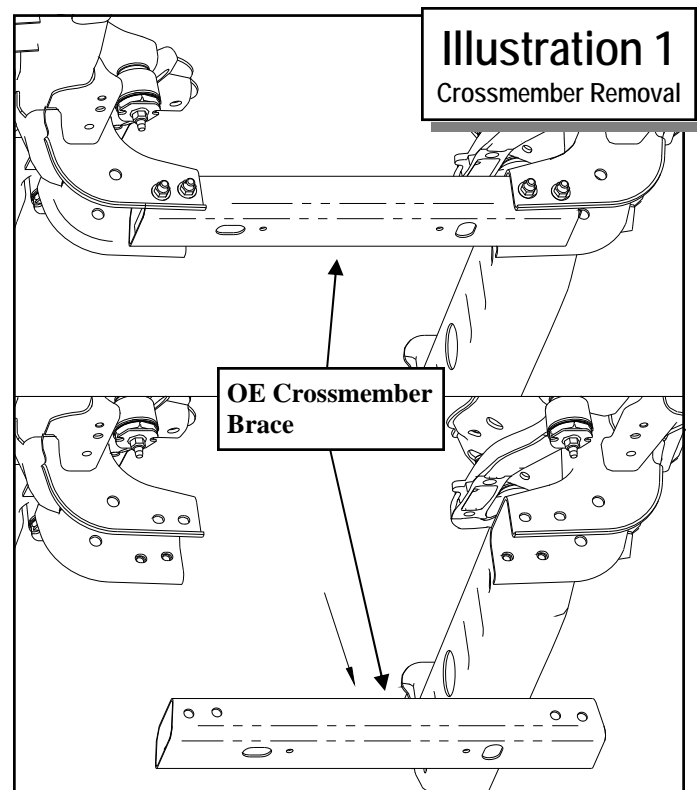

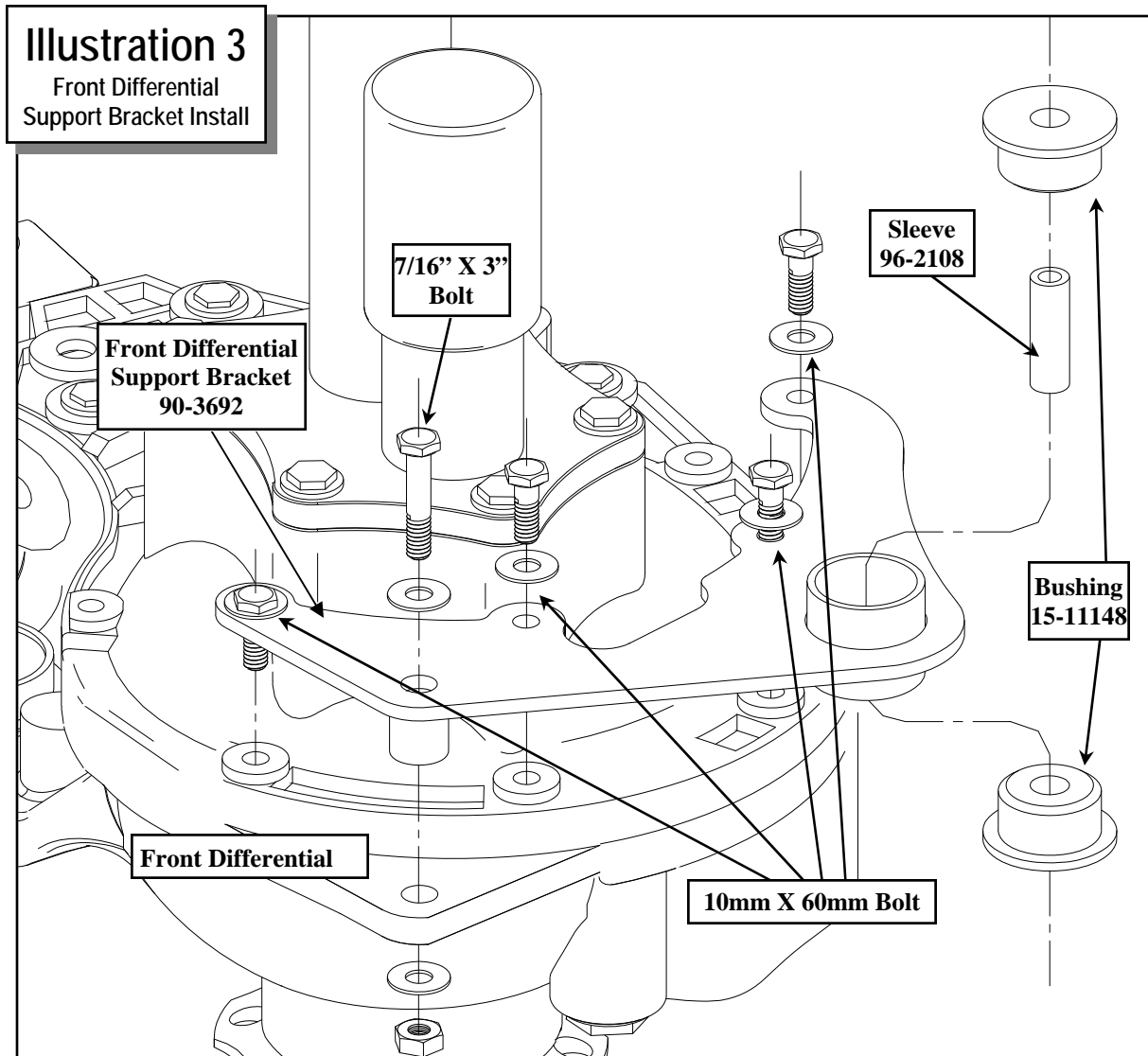
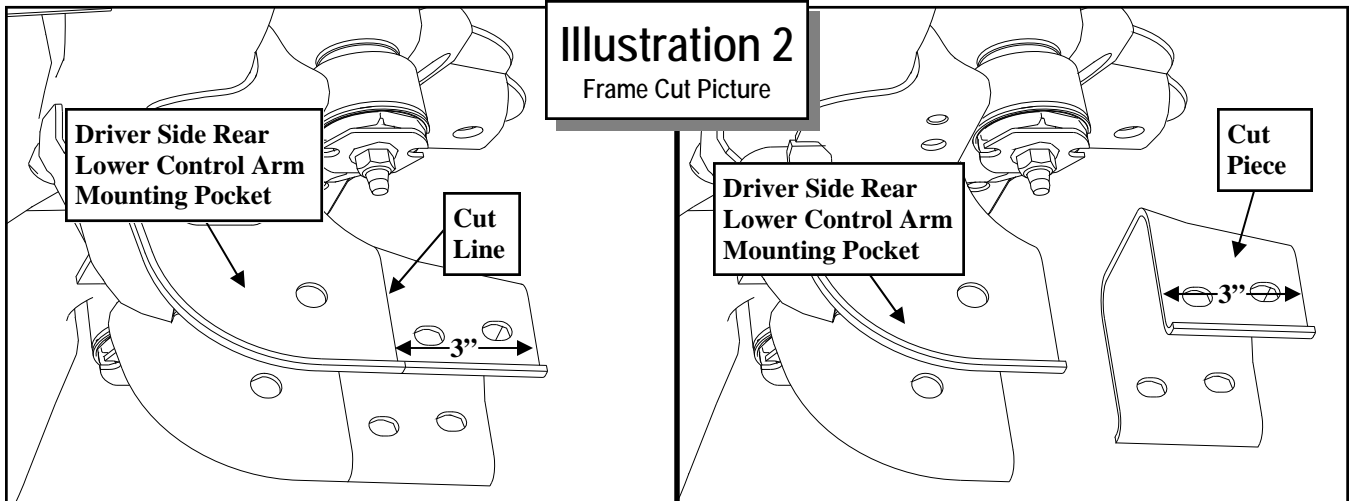



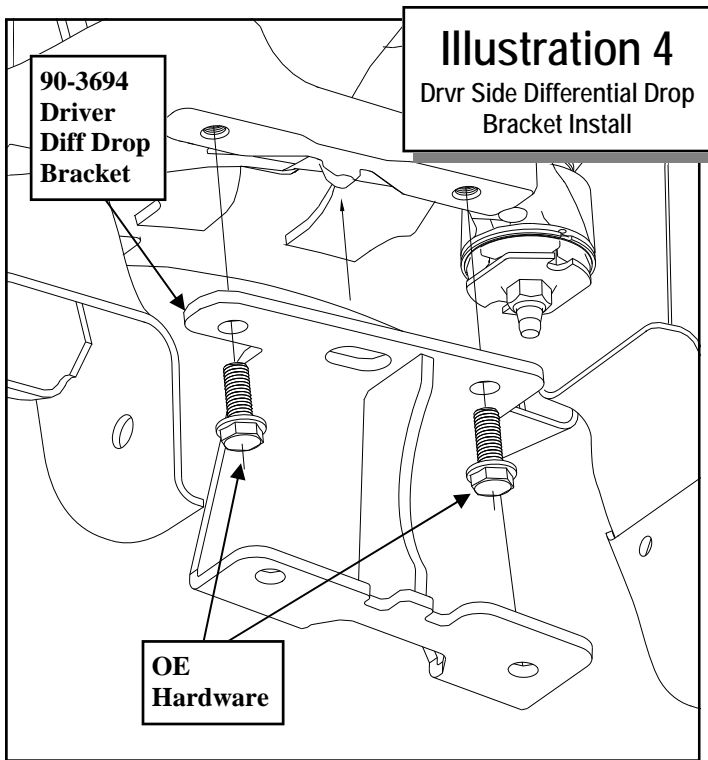

**Illustration 4**

Drvr Side Differential Drop Bracket Install

90-3694  
Driver  
Diff Drop  
Bracket

OE  
Hardware

brace from the vehicle and discard. See ILLUSTRATION 1.

23. Support the differential with a jack and unbolt the driver and passenger side mounts (2 per side). Carefully remove the differential from the vehicle.

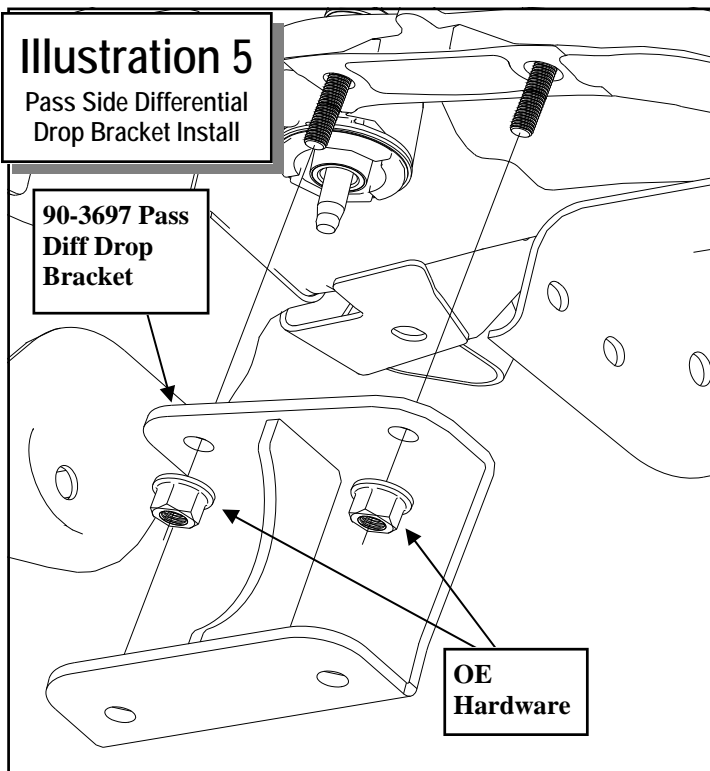

**Illustration 5**

Pass Side Differential Drop Bracket Install

90-3697 Pass  
Diff Drop  
Bracket

OE  
Hardware

24. On the driver side **ONLY**, measure out from the edge of the rear factory crossmember brace mount approximately 3" and scribe a line. See ILLUSTRATION 2.

25. Using a suitable cutting tool, (abrasive cutoff wheel, Sawz-all, etc.) cut the frame along the previously marked lines as shown in ILLUSTRATION 2.

26. Assemble the front differential support bracket (90-3692) using the supplied bushings (15-11148) and sleeves (90-2108) from hardware pack (90-6515). See ILLUSTRATION 3.

27. Rotate the front differential until the case bolt heads are oriented up. Carefully remove the factory bolts from the differential as shown in ILLUSTRATION 3.

*NOTE: You will probably notice some differential oil seeping from the area where the bolts are removed. This is normal and not something to worry about.*

*If you do not stand the differential as directed, you will see a LOT more oil on your floor.*

28. Place front differential support bracket (90-3692) on the front differential as shown in ILLUSTRATION 3. Secure support bracket using the supplied 10mm X 60mm bolts and washers, 7/16" X 3" bolt and hardware from pack 90-6251. Torque these fasteners to 32 ft. lbs. See ILLUSTRATION 3.

29. Install the driver side differential drop (90-3694) into the factory frame location using the OE bolts and hardware. Hand tighten only. ILLUSTRATION 4.

30. Using the OE hardware, install the passenger side differential drop (90-3697) to the factory frame location as shown in ILLUSTRATION 5.

*IMPORTANT: The bracket is slightly tapered. The short end of the taper is oriented toward the rear of the vehicle.*

31. Secure the differential to the previously installed drop brackets (90-3694 Drvr and 90-3697 Pass) using the supplied hardware. Snug all differential mounting hardware to secure the differential location at this time, but **DO NOT** torque at this time. See ILLUSTRATIONS 6.

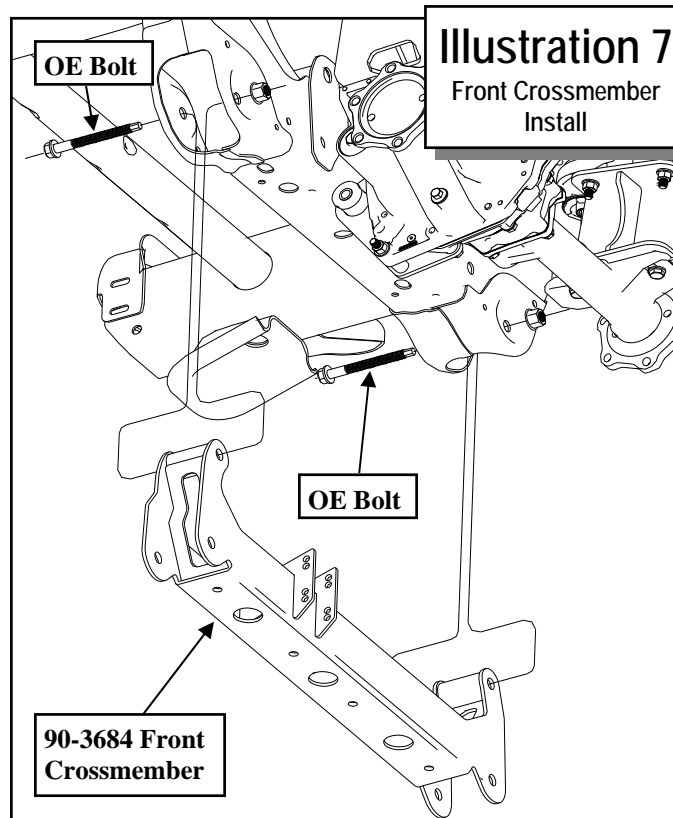
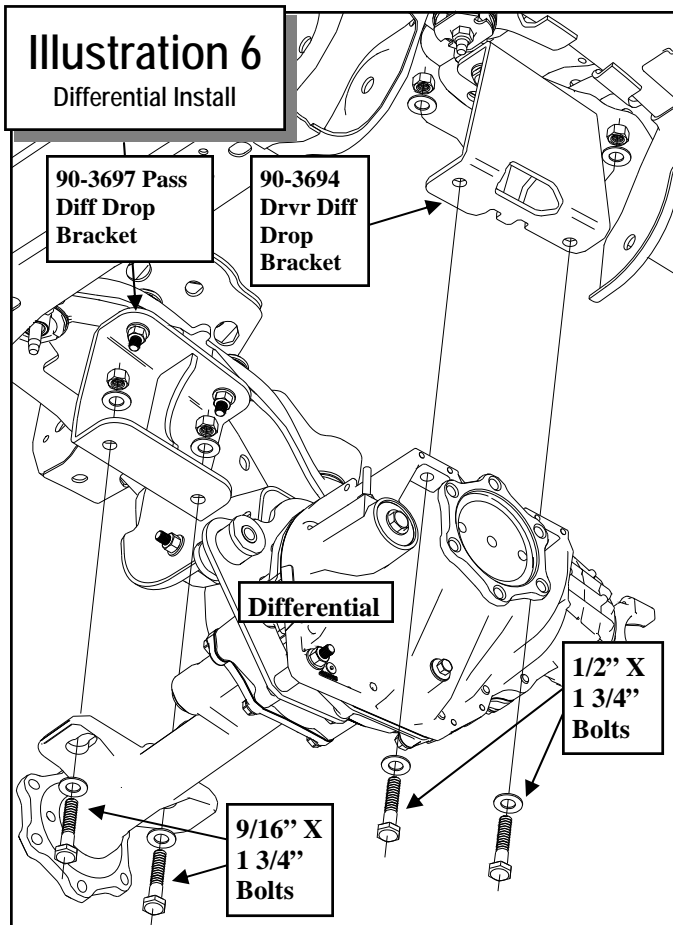

32. Check clearance between the differential and the trimmed area of the frame. If needed, remove more material until adequate clearance is achieved.
33. After verifying there is an adequate amount of clearance, thoroughly clean and paint the trimmed areas with a good quality paint to prevent rust.
34. Install the front crossmember (90-3684) into the front mounting pockets by sliding one end of the crossmember into the driver side mounting pocket from the outside. Push the installed end of the crossmember as far as it will go to the passenger side in the mounting pocket. Swing the crossmember up into the passenger side pocket. Center the crossmember in the mounting pockets and secure using the OE bolts. See ILLUSTRATION 7.

**NOTE:** *DO NOT* cut the front crossmember frame mounting pockets.

35. Install the front differential tabs (90-3691), from hardware pack (90-6516), to the lower holes in the welded mounting tabs on the front crossmember using the supplied 5/16" X 1" bolts and hardware. See ILLUSTRATION 8.

**NOTE:** *Be sure to bolt the tabs (90-3691) to the outside of the welded crossmember mounting tabs.*

36. Secure the diff mount tabs to the front differential support bracket (90-3692) using the using the 9/16" X 4" bolt and hardware.
37. Install the rear crossmember (90-3688) into the rear mounting pockets using the OE bolts. See ILLUSTRATION 9.

**NOTE:** *Be sure to check for clearance against the frame.*

38. Install the front supplied Pro Comp driveshaft (90-4051) to the front differential and transfer case using the previously removed OE hardware.
39. Reattach the wiring harness, wiring clips and the vent tube to the differential.

**IMPORTANT:** *Secure the vacuum line out of the way of the steering rack.*

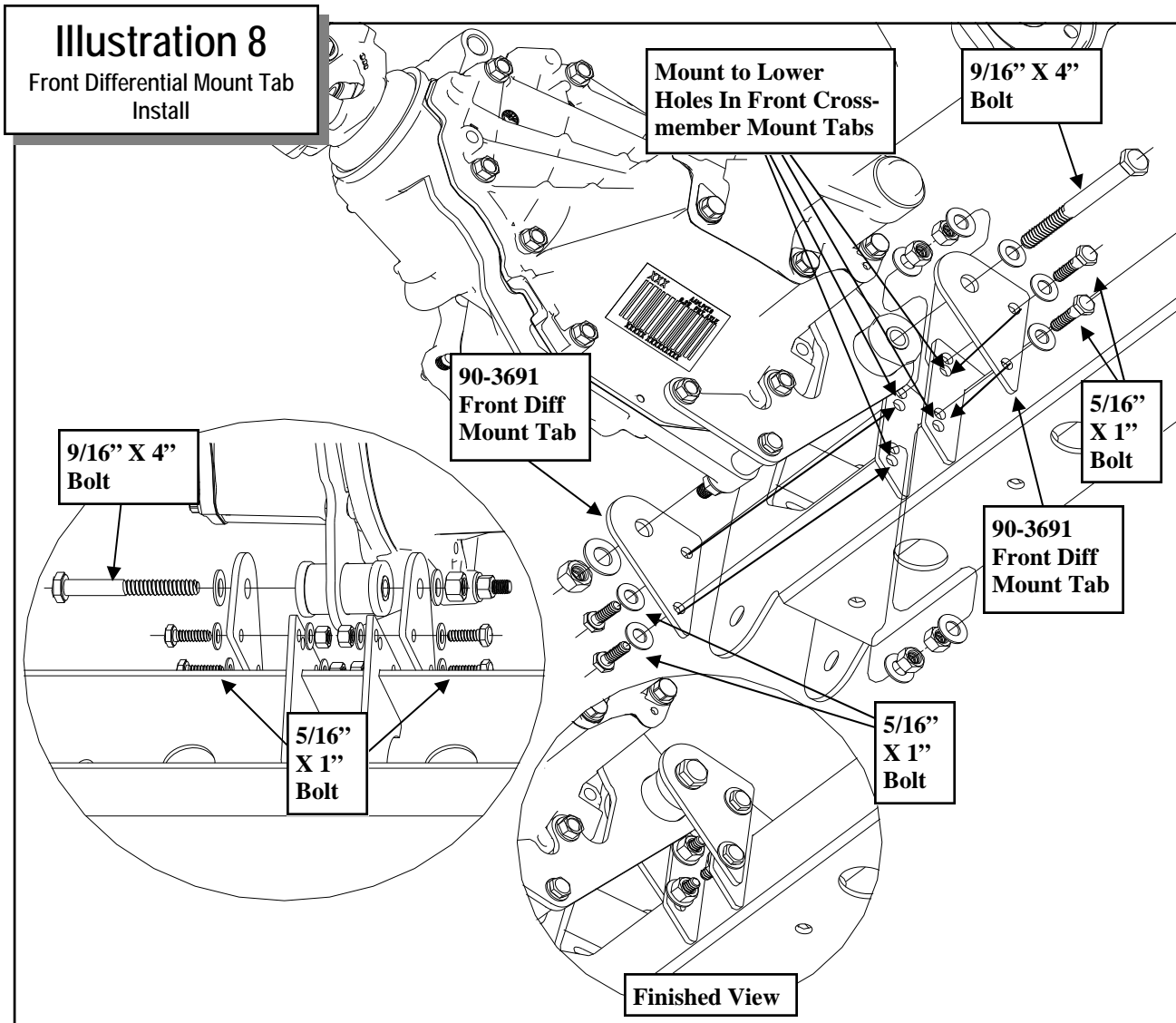

**NOTE:** *The differential vent tube may need to be carefully pulled down to provide more slack for it's new mounting position.*

40. Unbolt the CV axle retaining nut and remove the CV axle from the **OE** knuckle.
41. Separate the knuckle from the lower control arm and remove the **OE** knuckle.
42. Disassemble the **OE** knuckle on your work bench, remove the bearing hub assembly from the **OE** knuckle by removing the **OE** bolts. Save the mounting bolts, bearing, and dust shield for re-use. Discard the **OE** knuckles.
43. Reassemble the bearing hub and brake dust shields into the new Pro Comp steering knuckle (**90-4491 Drvr** and **90-4492 Pass**). Make sure that the ABS wiring is oriented in exactly the same position as it came from the **OE** knuckle and out of the way of the tire.
44. Torque the bearing to the knuckle with the **OE** bolts. Torque to 133 ft./lbs. Repeat on the other side.
45. Install the lower A-arms into the crossmember mounting pockets. Secure using the supplied **5/8\" X 4 1/2\"** bolts and hardware in the front pocket and the supplied **5/8\" X 5 1/2\"** bolts and hardware in the rear pocket.
46. Install the new knuckle to the lower ball joint. Torque the lower ball joint nut 74 ft./lbs.
47. Slide the CV spacer ring (**90-3809**) onto the splined end of the outer CV axle. Be sure that the tapered end of the ring is facing toward the inside of the axle. Slip the CV axle through the

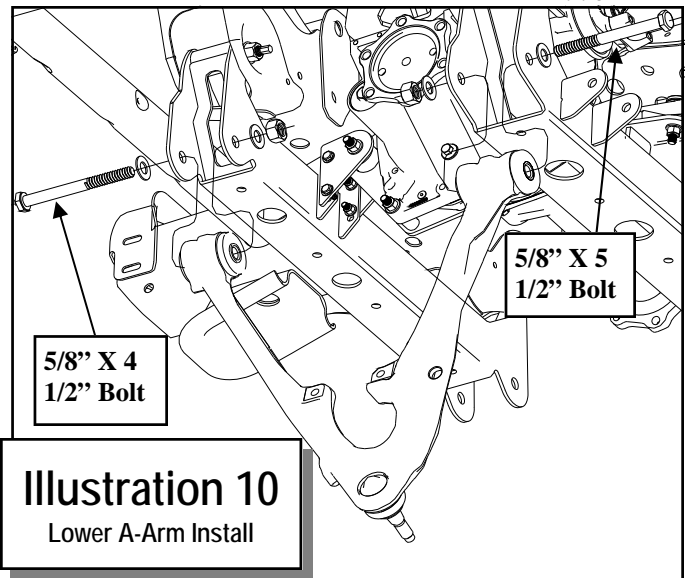
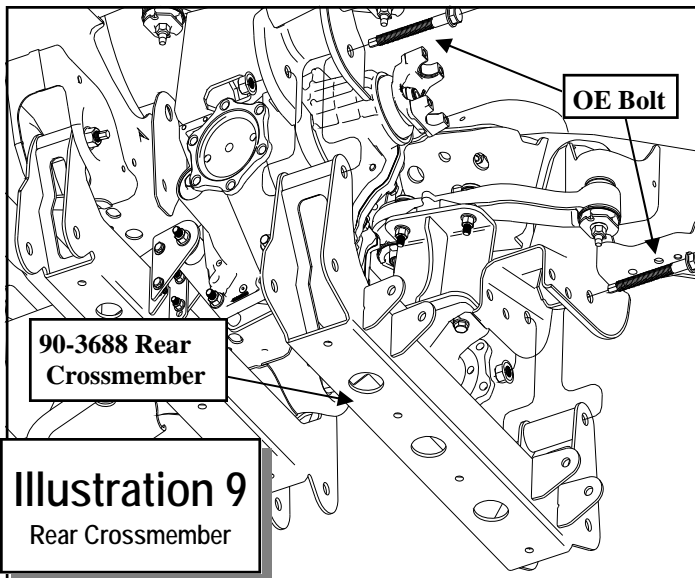

- bearing hub in the knuckle from the inside.
48. Secure the CV axle and the CV spacer (90-4077) to the differential using the supplied 10mm X 60mm bolts and washers. See ILLUSTRATION 11.
  49. Install the new knuckle to the upper ball joint. Start the nut and leave hand tight until Coil over installation is complete.
  50. Reinstall the CV shaft washer and retaining nut to CV axle. Torque this nut to factory specifications. (See your GM service manual for details)
  51. **WITH THE COIL OVERS**, insert the mono ball spacers (90-2433) from pack (90-6492) in the top of the coil over as shown in ILLUSTRATION 12.

*NOTE: The spacers are a tight fit. A press*

- might be needed to fit the spacers into the mono balls.*
52. Install the new Pro Comp coil over shock (624000) to the upper bracket (90-3712) with the supplied 1/2" X 2 3/4" hardware from hardware pack (90-6318).
  53. Install the 1/4" spacer (90-3956) onto the upper coil over mount upper bracket studs. See ILLUSTRATION 12.
  54. Fasten upper bracket to the vehicle using the supplied 7/16" hardware on the top from hardware pack (90-6317) and torque to 45-50 ft./lbs. See ILLUSTRATION 12.
  55. Secure the lower coil over shock cross pin to the lower A-arm using the supplied 7/16" X 2 1/2" bolts and hardware. Torque according to the

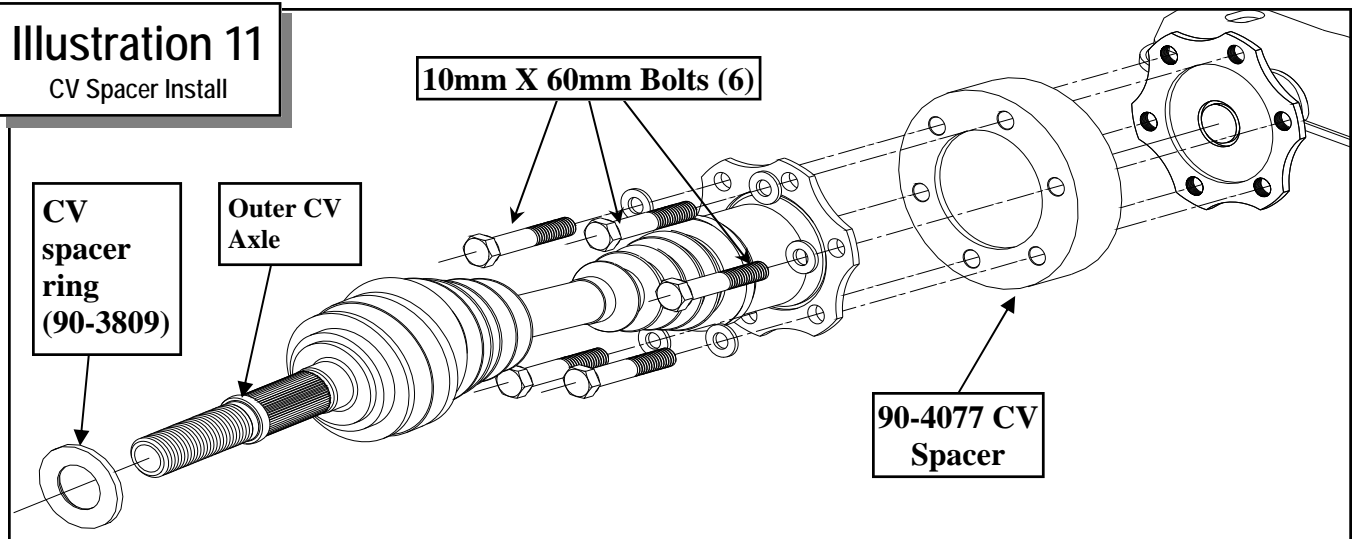

**Illustration 12**  
Coil Over Install

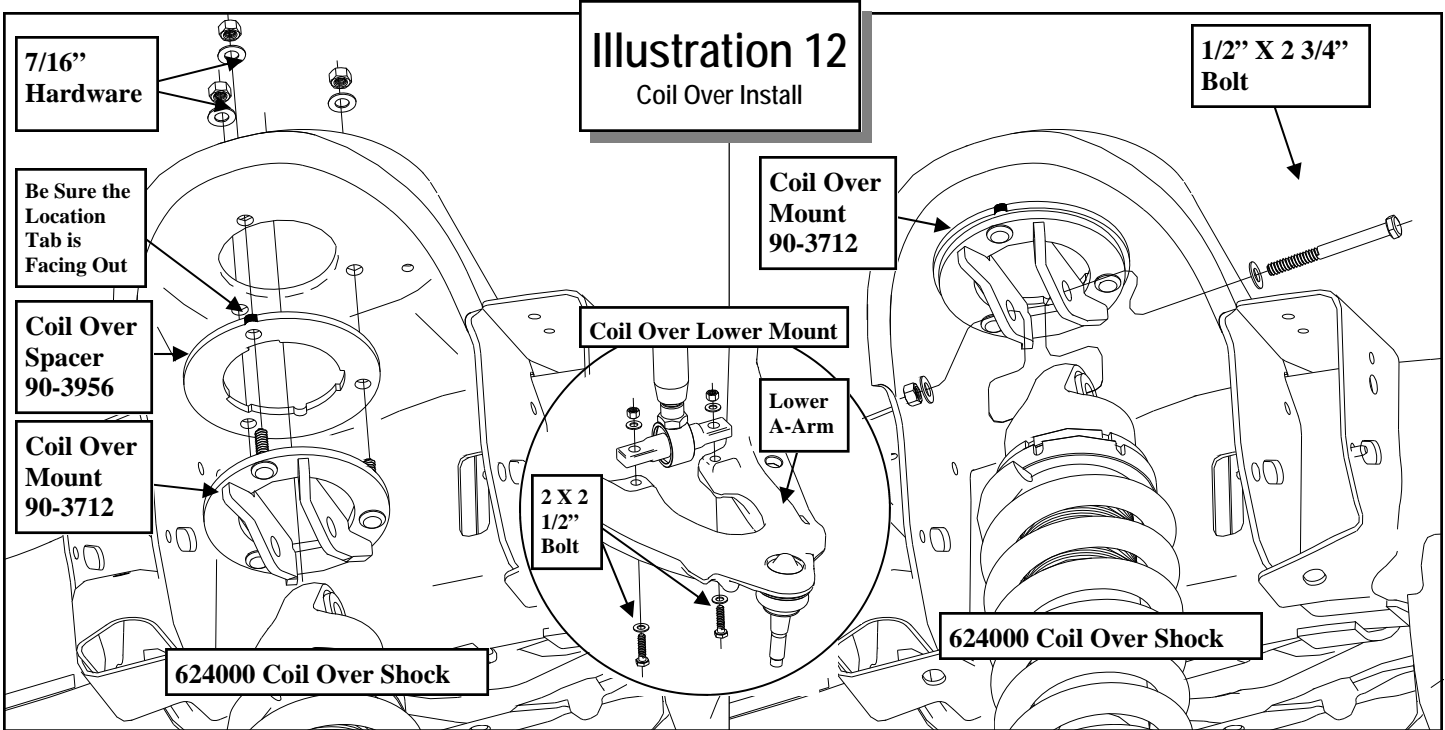

**Illustration 13**  
Strut Spacer Install

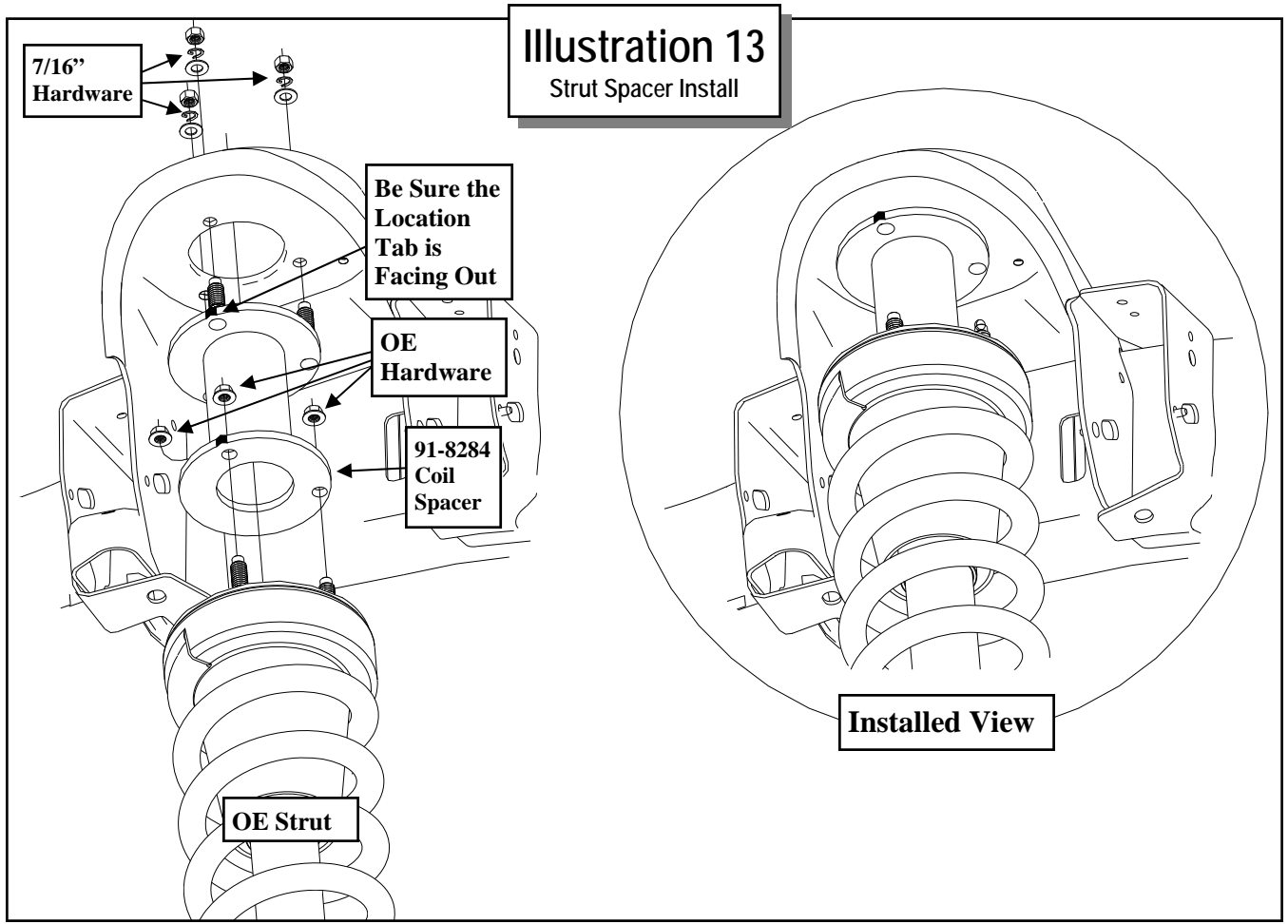

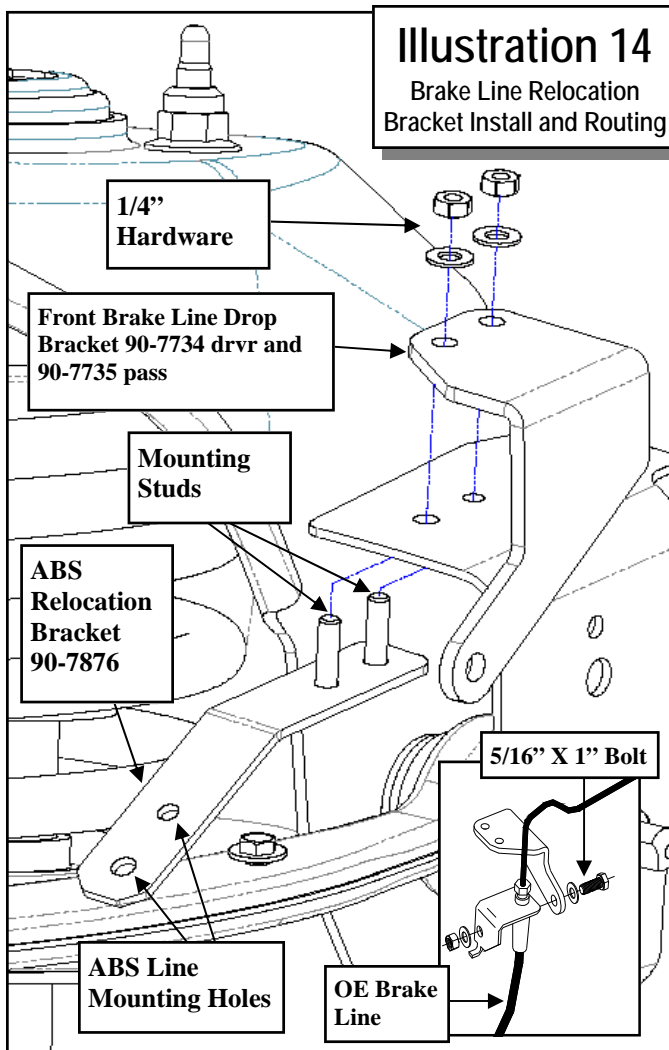

chart on page 19. See ILLUSTRATION 12.

**NOTE: Supplemental instructions for MX coil over installation are located in box 51017BMX-7/51207BMX-1.**

56. **WITH THE STRUT SPACERS**, attach the strut spacer (91-8284) to the top of the strut using the OE hardware. Torque to manufacturers specifications.
57. Fit the strut and spacer assembly into the stock mounting locations. Fasten using the supplied hardware on the top from hardware pack (90-6317) torque to 45-50ft./lbs. See ILLUSTRATION 5.  
**NOTE: Be sure that the locating tab on the top ring of the strut spacer is facing toward the outside of the vehicle.**
58. Secure the lower strut cross pin to the lower A-arm using the OE bolts. Torque the bolts according to the manufacturers specifications. See ILLUSTRATION 5.
59. Repeat steps 51 through 55 (for use with coil over) or 56 through 58 (for use with OE strut) on the remaining side of the vehicle.
60. Torque the upper ball joint nut to 37 Ft./lbs.
61. Be sure to re-clip the previously removed upper strut mount wiring away from any moving parts, steering shaft or exhaust manifolds.

62. Work on one side of the vehicle at a time.
63. Torque all the differential, upper crossmember bolts and coil over hardware according to the torque chart on page 19 or to factory specifications. **DO NOT** torque the lower A-arm until the vehicle is on the ground.
64. Unbolt the rubber brake line bracket from the upper coil bucket. Discard the OE bolt.
65. Unclip the OE metal brake lines from the frame clips and carefully bend to provide enough slack in the line for it's new position.

**NOTE: Be sure that the metal lines do not rub or contact anything.**

66. Install the ABS line relocation bracket (90-7876) studs, from the bottom, into the existing holes in the rear of the upper control arm pocket. Install the brake line relocation bracket (90-7734 drv

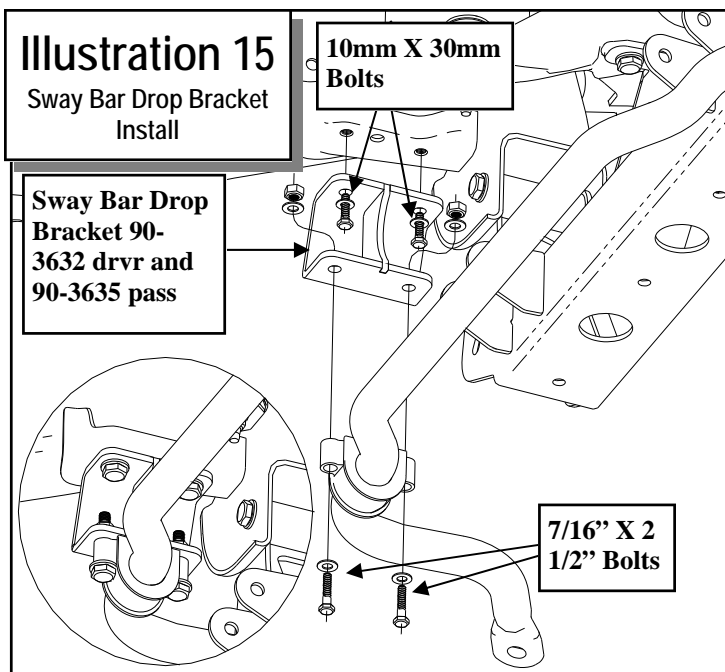

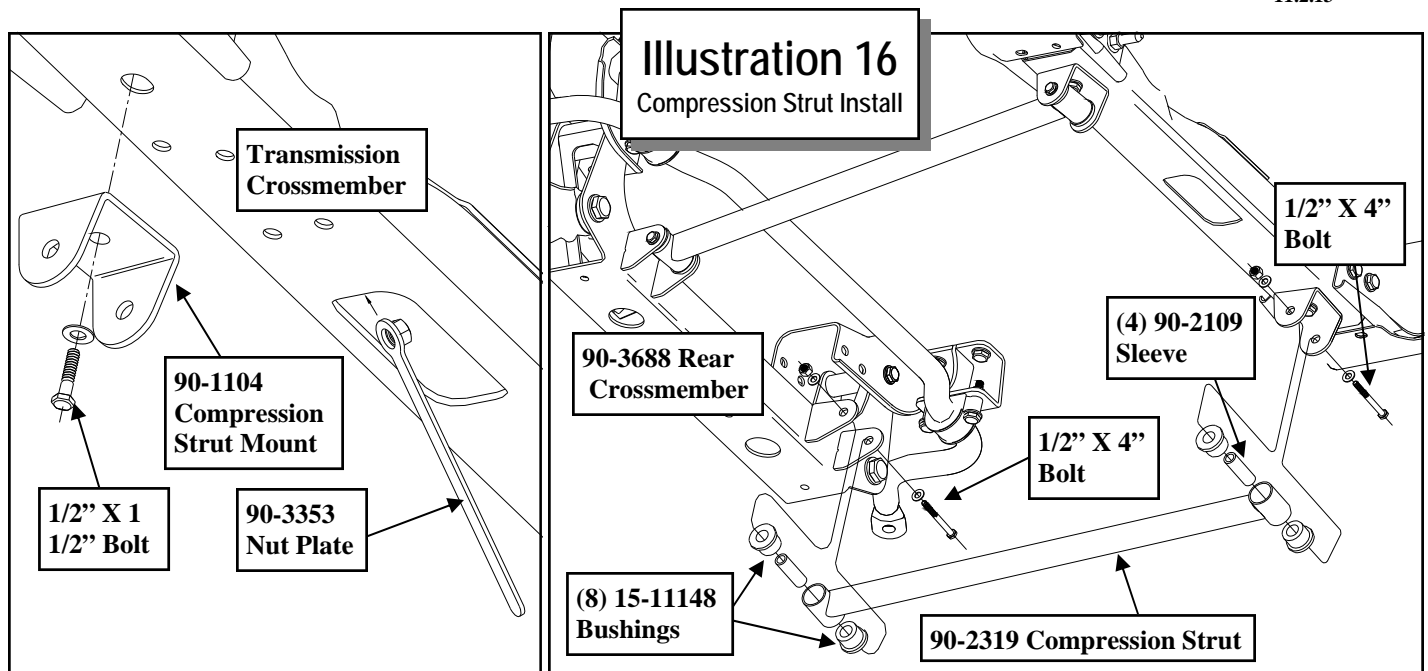

and **90-7735 pass**) to the ABS relocation bracket mounting studs. Secure using the supplied **1/4"** washers and nuts. See ILLUSTRATION 14.

67. Bolt the brake line to the previously installed brake line relocation bracket (**90-7734 drv**r and **90-7735 pass**) using the supplied **5/16" X 1"** bolt. See ILLUSTRATION 14.

68. Reinstall the rotors and brake calipers to the new knuckle using the previously removed **OE** bolts. Be sure to use thread locker on the caliper bracket mounting bolts. Torque to factory specifications.

**NOTE: It may be necessary to carefully bend the caliper banjo fitting slightly up to provide adequate slack for the brake line. Be very careful not to damage the banjo fitting or brake line in any way. Check tightness of banjo bolt after modification.**

69. Route the ABS wire through the factory clips on the upper A-arm. Secure the ABS line to relocation bracket (**90-7876**) mounting holes. The ABS line plastic push pin will install to one hole and the locating tab will install into the remaining hole. See ILLUSTRATION 14.

**NOTE: On some vehicles the driver's side OE wire harness that connects to the ABS wire may be shorter, from the factory, than others. If the line needs to be extended GM #19149296 (ACD#PT2232) can be installed into the chassis wire harness.**

70. Reattach the ABS wiring and secure it to the top hole on the knuckle using the supplied Adel clamp and supplied **OE** bolt and washer. See ILLUSTRATION 14.

**NOTE: The Adel clamp has a flat side and a rounded side, make sure the flat side is facing out toward the tire.**

71. On both sides of the vehicle loosen the jam nut and remove the outer tie rod ends and jam nuts.

72. The inner and outer tie rod ends may need to be shortened. Measure in **9/16"** from the end of the inner tie rod end and scribe a line. Measure in **7/16"** from the end of the outer tie rod end and scribe a line. Using a suitable cutting tool, (abrasive cutoff wheel, Sawz-all, etc.) cut the ends along the previously marked line. Be sure the cut is made straight and square or else the jam nut will not hold it's torque properly.

73. Install the supplied **16mm** jam nuts onto the inner tie rods. Thread the jam nut and outer tie rod ends on as far as they will go on the inner tie rods with the stud facing down.

74. Reinstall the outer tie rod ends onto the inner tie rod ends. Thread them on as far as they will go with the stud facing down.

75. Insert from the top and secure the tie rod end to the knuckle and torque to factory specifications. Be sure to clean the threads and use thread locking compound on the tie rod end nut.

76. Install the sway bar drop brackets (**90-3632 driver** and **90-3635 pass**) to the original sway bar mounting holes in the frame, angled toward the rear of the vehicle, using the supplied **10mm-1.5 X 30mm** bolts and hardware. See ILLUSTRATION 15.
77. Using the previously made sway bar orientation markings as a guide, flip the sway bar **180** degrees and reinstall it to the sway bar drop brackets using the supplied **7/16" X 2 1/2"** bolts and hardware. Leave hardware loose at this time. See ILLUSTRATION 15.
78. Install the previously removed **OE** sway bar end links into their original location on the lower A-arms. See ILLUSTRATION 15.
79. Reconnect the sway bar end links to the sway bar.
80. Torque the sway bar hardware according to the torque chart on page 19.
81. Install the bushings (**15-11148**) and sleeves (**90-2109**) from hardware pack (**90-6263**) into the compression struts (**90-2319**).
82. Using the existing outer holes attach the compression strut mounts (**90-1104**) to the transmission crossmember. Use the supplied **1/2" X 1 1/2"** bolt and nut plate (**90-3353**) to secure the mounts to the crossmember. See ILLUSTRATION 16.
83. Rotate the compression struts up and secure them to the crossmember mounts using the supplied **1/2" X 4"** bolt and hardware. See ILLUSTRATION 16.  
*NOTE: The wires can be trimmed off the end of the comp strut nut plates at this time.*
84. Torque compression strut hardware according to the torque chart on page 19.
85. On both sides of the vehicle, check the routing of the brake lines and the ABS wire harnesses. There must be no pinching, rubbing, or stretching of either component. Use zip ties to secure these items to the steering components. At full droop, cycle the steering from lock to lock while observing the reaction of these components. Check the caliper banjo fitting to ensure the line has the proper amount of slack. Reposition them if needed.
86. With the front wheels installed cycle the steering from lock to lock to check to make sure the front wheels have enough clearance in the wheel well. If the wheel contacts the front or rear of the wheel well some trimming will be necessary.  
*NOTE: Remove OE rotor/drum retaining clips from wheel studs before installing the wheels.*
87. Lower the vehicle to the ground. Torque the lug nuts according to the wheel manufacturers recommendations.
88. With the truck on the ground torque the lower A-arm bolts according to the torque chart on page 19.
89. Center the steering wheel and lock it in place. Set the toe by adjusting the tie rod ends properly.  
*IMPORTANT!: If the steering wheel and front wheels are not centered properly it will trigger the anti-lock brake and traction control warning lights.*
90. Lock the outer tie rod ends by tightening the **16mm** jam nuts.
91. Recheck all hardware for proper installation and torque at this time.  
*IMPORTANT! BE SURE TO BRING THE VEHICLE IMMEDIATELY TO A REPUTABLE ALIGNMENT SHOP TO BE ALIGNED!*

**NOTES:**

- ⇒ **On completion of the installation, have the suspension and headlights re-aligned.**
- ⇒ **After 100 miles recheck for proper torque on all newly installed hardware.**
- ⇒ **Recheck all hardware for tightness after off road use.**



# REAR INSTALLATION:

51017B/51017BMX  
Revised  
11.2.13

1. Raise the rear of the truck enough for the tires to clear the ground and use jack stands on the frame to support the truck. Remove the rear tires and wheels.
2. Carefully remove the **OE** shock absorbers. It may be necessary to raise the differential housing slightly to facilitate their removal.
3. Unbolt the driver side emergency brake line hanger from the frame rail. Save the **OE** bolt for reuse.
4. Unclip the rubber ABS line from the frame rails.
5. Unbolt the rear brake line bracket from the rear axle differential housing. Save the **OE** bolt for reuse.

6. One side at a time, support the differential housing on the side being modified. Remove the “U” bolts from that axle end and discard. Carefully lower the differential away from the **OE** springs. Remove and discard the **OE** riser block from its mount pad. Take careful note of the position of the factory spring packs.

## ADD-A-LEAF (13127-1) INSTALLATION

**NOTE:** In order to properly install the add-a-leaf spring, it will be necessary to contain the elasticity in the leaf spring with “C” clamps when the center bolt is removed. Some springs have a factory helper spring consisting of one or more flat leaves installed at the bottom of the leaf pack. **DO NOT** install the add-a-leaf spring in or below the helper spring.

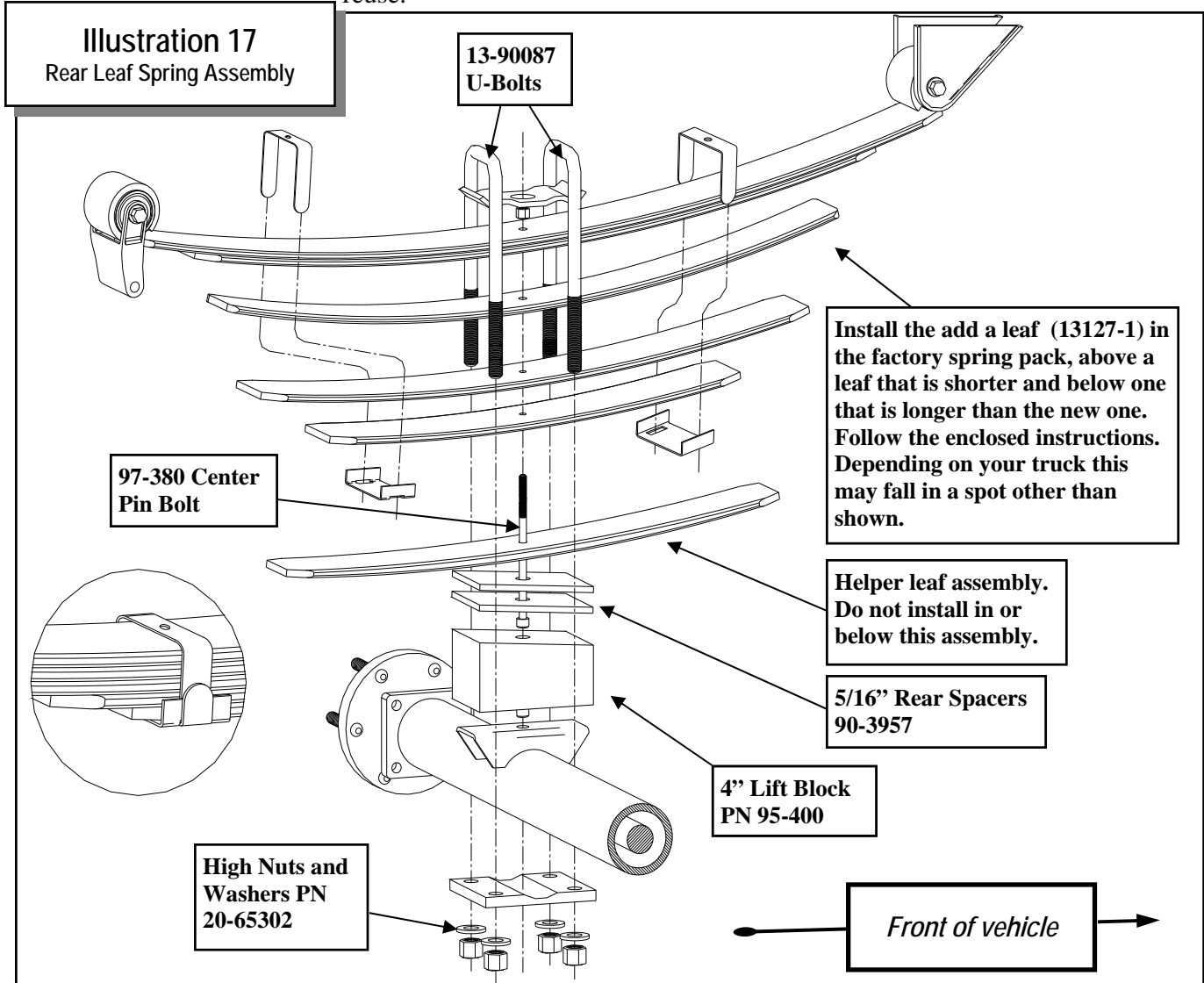

7. Hold the spring assembly securely together with “C” clamp. If necessary remove any spring leaf alignment clamps. Remove the spring center bolt. A hammer and drift punch may be used to drive it out if necessary.
8. Carefully remove “C” clamps and lay unassembled leaves aside.  
**NOTE: Add-a-leaf will be placed in the spring assembly progressively according to length. For example, if the existing leaves are 32” long and 25” long and the add-a-leaf is 28” long, place the add-a-leaf between the existing leaves.**
9. Apply a small amount of grease to the end of the add-a-leaf, place it in the spring assembly as described in the note above, and reassemble the leaf springs using the “C” clamps. Insert the new center bolt (97-380) and the (2 *per side*) 5/16” spacer plate (90-3957) under the factory overload spring. Torque the center bolt nut to 20 ft./lbs. With a hacksaw, cut the center bolt even with the top of the nut. **NOTE: The short side of the spacer will face toward the front of the vehicle.**
10. Loosely assemble the complete spring assemblies into their respective axle mounts. As shown in **ILLUSTRATION 19**, place the 4” (95-400) blocks in position. Make sure the pin in the block is in the hole of the axle housing spring pad. The short end of the block goes toward the front of the vehicle. Install the block so the pinion moves up.
11. Install the new “U” bolts (13-90087) over the leaf spring assembly and using the new washers and nuts supplied along with the existing spring plates, torque the U-bolt nuts to 105 ft./lbs. See **Illustration 19**.
12. Repeat these steps on the other side of the vehicle.
13. Reattach the emergency brake line hanger to the frame rail using the previously removed OE bolt.
14. Bolt the rear brake line extension bracket (90-3341) to the rear axle differential housing using

the previously removed OE bolt.

15. Carefully rotate the rubber brake line factory bracket assembly toward the rear of the vehicle and bolt it to the newly installed extension bracket (90-3341) using the supplied 5/16” X 1” bolt and hardware from pack (90-6299).  
**NOTE: Be sure that the metal lines do not rub or contact the rear end housing.**
16. Before installing your new Pro Comp shock absorbers, it is necessary that you check for adequate clearance. Temporarily install your Pro Comp shocks (928001 or MX6098) into the shock mounts. Carefully check for clearance issues. If there are areas that come in contact with or are very close to your new shocks, carefully remove sufficient material to ensure trouble free operation. Pay particular attention to the area around the lower shock mount. When all clearance issues have been resolved, install your new Pro Comp shock absorbers and recheck all fasteners for proper installation and torque. You can install only the MX6 shocks either shaft up or shaft down.
17. Install your wheels and tires and lower the vehicle to the ground.  
**NOTE: Remove OE rotor/drum retaining clips from wheel studs before installing the wheels.**
18. After installation is complete, double check that all nuts and bolts are tight. Refer to the chart at the end of this document for torque specifications. (Do not retighten nuts and bolts where thread locking compound was used).

**NOTES:**

- ⇒ **On completion of the installation, have the suspension and headlights re-aligned.**
- ⇒ **After 100 miles recheck for proper torque on all newly installed hardware.**
- ⇒ **Recheck all hardware for tightness after off road use.**
- ⇒ **If upon completion the vehicle sit higher than desired, height can be taken out by removing one of the 5/16” spacers from the rear spring pack.**

## Final notes:

1. If new tires are installed that are more than 10% taller than original tires, the speedometer must be recalibrated for the rear wheel anti-lock brake system to function properly. Contact an authorized GM dealer for details on recalibration.
2. With vehicle on the floor, cycle the steering from lock to lock and inspect the steering, suspension and driveline systems for proper operation, tightness and adequate clearance. Recheck brake hose/fittings for leaks. Be sure all brake lines are long enough for safe operation.
3. Have headlights readjusted to the proper settings.
4. Realign front end to factory specifications. Be sure the vehicle is at the desired ride height prior to realignment.
5. Recheck ALL fasteners at 100 miles to make sure they have not come loose. Due to the additional wear and tear created by larger tires and wheels, we recommend that you periodically check the suspension system and steering components to ensure service life and safe vehicle operation.

<b>Bolt Torque and ID</b>						
<b>Decimal System</b>			<b>Metric System</b>			
All Torques in Ft. Lbs.						
Bolt Size	Grade 5	Grade 8	Bolt Size	Class 9.8	Class 10.9	Class 12.9
5/16	15	20	M6	5	9	12
3/8	30	45	M8	18	23	27
7/16	45	60	M10	32	45	50
1/2	65	90	M12	55	75	90
9/16	95	130	M14	85	120	145
5/8	135	175	M16	130	165	210
3/4	185	230	M18	170	240	290

 <p>1/2-13x1.75 HHCS    <b>Grade 5    Grade 8</b>                  (No. of Marks + 2)</p> <p>D    T    L    X</p>	 <p>M12-1.25x50 HHCS</p> <p>D    T    L    X</p>
<p>G = Grade (Bolt Strength)                  D = Nominal Diameter (Inches)                  T = Thread Count (Threads per Inch)                  L = Length (Inches)                  X = Description (Hex Head Cap Screw)</p>	<p>P = Property Class (Bolt Strength)                  D = Nominal Diameter (Millimeters)                  T = Thread Pitch (Thread Width, mm)                  L = Length (Millimeters)                  X = Description (Hex Head Cap Screw)</p>

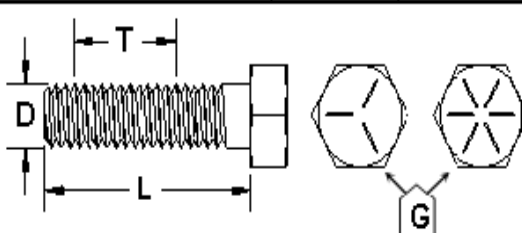
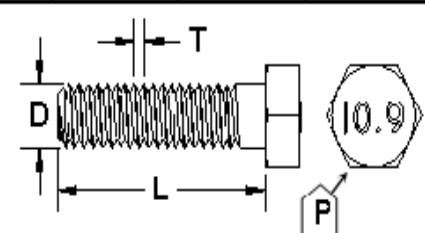
## **Revision Page:**

**11.2.2011:** Changed front brake line brackets from **(90-3573 drvr and 90-3574 pass)** to **(90-7734 drvr and 90-7735 pass)** in BOM box 4 and text and illustration #14. Updated the quantity of hardware pack **(90-6522)** from (1) to (2) in BOM box 2. Updated kit fitment to include 2012.

**8.27.2012:** updated kit fitment to include through 2013. Added driveshafts 51246 and 51247 to the options box.

**10.2.2012:** Changed the knuckle part numbers to **90-4491** drvr and **90-4492** pass in BOM box-2 and the text.

**10.16.2012:** Added GM ABS line extension adapter information to page 5.

**12.8.2012:** Added ABS Relocation Bracket **(90-7876)** to the BOM box-4, text steps and Illustration 14.

**4.8.13:** Updated cover logo, warranty page and contact information.

**11.2.2013:** Changed the strut spacer part numbers to **90-2614** drvr and **91-8284** pass in BOM box-6 and the text.



51017B/51017BMX  
Revised  
11.2.13

## TECHNICAL BULLETIN

BULLETIN #: 000018

DATE: 7/1/08

RE: 07-08 Chevy/ GMC 1500 P/U & SUV 2WD/ 4WD Vehicles with Inner Edge Tire Wear

PART #: 51007B/BMX – 51017B/BMX – 51227B/BMX – 51907B/BMX – 51927B/BMX -  
51947B/BMX

In monitoring our technical service inquiries, we've identified the potential for premature inner edge tire wear on 07-08 Chevy/ GMC 1500 P/U's & SUV's.

Our R&D team tested a prototype vehicle under normal driving conditions and due to various spring rates from the factory, a toe-in total setting of **5/16" – 11/32" or .63 – 1.01 total degrees (.315 - .505 degrees per side)** has been determined to be the best alignment for drive-ability and tire wear.

As with any alignment, all adjustable angles must be inspected and brought into manufactures specifications before making the final toe setting. After setting the toe-in, test drive and check the vehicle for pulling, drifting, and or any related alignment issues, make any necessary adjustments to correct the problems, and re-check the toe-in setting.

Installation instructions will be updated in kits going forward and can be viewed on our web site. Please refer to kits 51007B/BMX – 51017B/BMX – 51227B/BMX – 51907B/BMX – 51927B/BMX - 51947B/BMX for a more detailed understanding of the toe-in setting at:

[http://www.explorerprocomp.com/tech\\_instructions.php](http://www.explorerprocomp.com/tech_instructions.php)

Please contact our Customer Service Tech Department at (800)-776-0767 or (619)-216-1444. They will be able to assist you with any questions you may have in regards to this issue.

### PRO COMP SUSPENSION

2360 BOSWELL ROAD  
CHULA VISTA, CA. 91914

TOLL FREE: (800)-776-0767 PHONE: (619)-216-1444 FAX: (619)-216-1474

[WWW.EXPLORERPROCOMP.COM](http://WWW.EXPLORERPROCOMP.COM)



## The PRO COMP PROMISE WARRANTY

At Pro Comp, we know you have many choices when selecting products to personalize your vehicle. You should demand nothing but the highest quality available and have total confidence that the products you selected are the best in the industry. It is for these reasons that Pro Comp Suspension products are backed by the best warranty in the industry...the Pro Comp Promise!

Pro Comp promises that its products will last a lifetime or we will replace it free of charge. It's that simple! Because of our commitment to quality and manufacturing excellence, we are able to stand behind our products. FOREVER.

It is Pro Comp's Promise that if one of our suspension products breaks not due to misuse, neglect or vandalism, we will replace it. Whether you are the original purchaser or not, you can be assured that we will make it right. The Pro Comp Promise covers all suspension products including shocks and steering stabilizers. Buy Pro Comp Suspension today and enjoy it for the rest of your life!

That's our Pro Comp Promise!

## Notice to Owner, Operator, Dealer and Installer:

Vehicles that have been enhanced for off-road performance often have unique handling characteristics due to the higher center of gravity and larger tires. This vehicle may handle, react and stop differently than many passenger cars or unmodified vehicles, both on and off-road. You must drive your vehicle safely! Extreme care should always be taken to prevent vehicle rollover or loss of control, which can result in serious injury or even death. Always avoid sudden sharp turns or abrupt maneuvers and allow more time and distance for braking! Pro Comp reminds you to fasten your seat belts at all times and reduce speed! We will gladly answer any questions concerning the design, function, maintenance and correct use of our products.

Please make sure that the Dealer / Installer explains and delivers all warning notices, warranty forms and instruction sheets included with Pro Comp product.

### Warranty and Return Policy:

Pro Comp warrants its full line of products to be free from defects in workmanship and materials for the life of the product. Pro Comp's obligation under this warranty is limited to repair or replacement, at Pro Comp's option, of the defective product. Any and all costs of removal, installation, freight or incidental or consequential damages are expressly excluded from this warranty. Pro Comp is not responsible for damages and / or warranty of other vehicle parts related or non-related to the installation of Pro Comp product. A consumer who makes the decision to modify his vehicle with aftermarket components of any kind will assume all risk and responsibility for potential damages incurred as a result of their chosen modifications. Warranty coverage does not include consumer opinions regarding ride comfort, fitment and design. Warranty claims can be made directly with Pro Comp or at any factory authorized Pro Comp dealer.

**IMPORTANT!** To validate the warranty on this purchase please be sure to mail in the warranty card.

### Claims not covered under warranty

\* Parts subject to normal wear; this includes bushings, bump stops, ball joints, tie rod ends and heim joints.

\* Finish after 90 days.

\* Damage caused as a result of not following recommendations or requirements called out in the installation manuals.

Pro Comp MX Series coil-over shocks are considered a serviceable shock with a one-year warranty against leakage only. Rebuild service and replacement parts will be available and sold separately by Pro Comp. Contact Pro Comp for specific service charges. Pro Comp accepts no responsibility for any altered product, improper installation, lack of or improper maintenance or improper use of our products.

**E-Mail:** [info@procompusa.com](mailto:info@procompusa.com)  
**Website:** [www.procompusa.com](http://www.procompusa.com)  
**Fax:** (310) 747-3912  
**Ph:** 1-800-776-0767

<b>PLACE</b> <b>WARRANTY REGISTRATION</b> <b>NUMBER</b> <b>HERE:</b> _____
---