

TERAFLEX

INSTALLATION GUIDE

Installation Guide for the Heavy Duty Short Shaft Kit

Part #004444401 (231SS-slip yoke eliminator kit)

Tera Manufacturing, Inc.
5251 South Commerce Dr.
Murray, Utah 84107
Phone/801.288.2585
Fax/801.713.2313
www.teraflex.biz



1987 models to present.

Reference numbers in **BOLD** refer to figure #3 attached.

A new rear drive shaft is required once this kit has been installed on the vehicle. This yoke kit is installed easiest if the transfer case is removed from the vehicle. This way, the 231J can be set in a vertical position on a bench making disassembly and assembly much easier and faster.

Jeep Cherokee applications:

TeraFlex Part# 231SS-X.

XJ vehicles with a front-axle vacuum disconnect switch will require the use of the 5/8"x18 threaded hole located on the new rear bearing retainer housing.

Low-Range Conversions:

If a TeraLow Low231 low-range conversion is being used, the switch can be placed in the front of the housing.

Instructions:

1. Put vehicle in gear and engage the emergency brake.
Remove the drain plug on the 231J and drain all of the fluid.
2. Remove the front and rear drive shafts from the vehicle.
3. Remove the front driveshaft yoke from the transfer case.
4. Remove the three metric bolts holding the rear seal retainer housing to the transfer case. Pry the rear retainer housing carefully to remove it from the transfer case. On TJ applications, remove the rubber boot and the stamped shield.
5. Using snap ring pliers, remove the bearing retainer snap ring (**#55**) from the 231J main shaft. Also, disconnect the speedometer cable from the t-case and remove the speedometer drive gear assembly from the rear bearing retainer housing.
6. Remove the metric bolts that attach the rear bearing retainer housing (**#59**) to the rear case half. Gently pry up the retainer and remove it.
7. At the rear of the case, you will notice a protruding steel rod. This rod is actually the end of the shift rail assembly (**#47**). As the transfer case is shifted from one gear to another, this shift rail will move forward or backward. Shift the transfer case until the exposed end of the shift rail is as far out as it will go. Place the new bearing retainer housing onto the rear case half as would occur during final assembly. Verify that the protruding shift rail does not bottom out into the pocket of the new bearing retainer housing. If interference does occur here, remove the new housing and shift the t-case until the shift rod is as far in as it will go. Using a cut-off wheel or grinder, cut the rail flush with the bushing (in the rear case half) that holds the rod in the case.

Snap Ring Installation:



When installing the rear bearing snap ring be sure to place it in a position that will not allow the speedometer driven gear to contact the snap ring. Use this photo as a reference.



Note: Verify the length of your mode fork shift rod as shown. If your shift rod measures 10.2", it will need to be cut down to a length of 9.380". This is typical of 1988 and 1989 model YJ's.

8. Remove the bolts holding the two transfer case halves (#3 & #49) together. Separate the case halves with a screwdriver using the indentations available on both sides of the t-case. The pump (#32) will be removed with the rear case half (#49).
9. Slide the shift rail spring off the shift rail (#48). See the figure below.

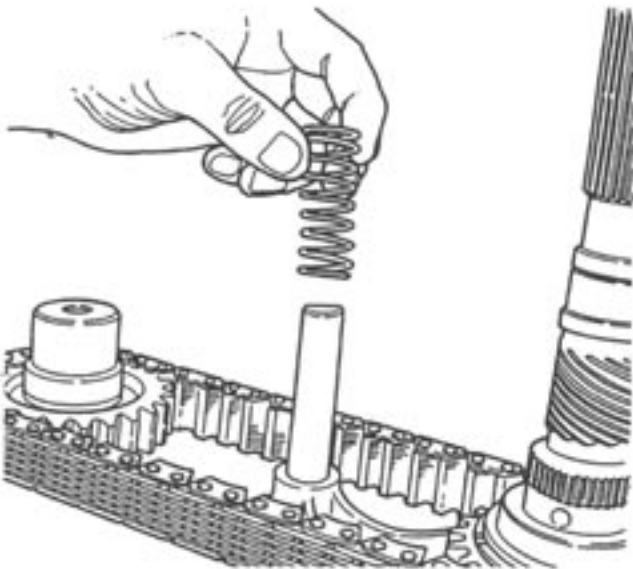

10. Holding the mainshaft and front drive sprocket, slide the entire assembly (chain included) rearward and out of the transfer case. The shift fork will come out with the assembly. See figure below.

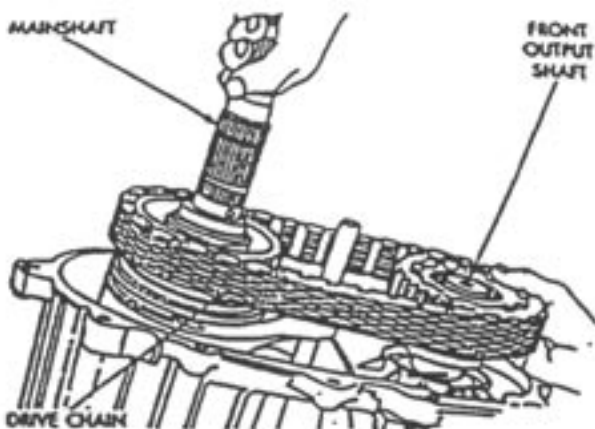

11. On the mainshaft, remove the snap ring (#14) holding the drive gear/synchronizer assembly in place. Slide the assembly down off of the shaft.
12. Slide the drive gear/synchronizer assembly down onto the new mainshaft supplied in the kit.
13. Place the flat shim on top of the gear assembly by passing it over the mainshaft. This shim will now be located directly below the snap ring groove in the mainshaft.
14. Install the snap ring that was removed in step 11.
15. Place the mainshaft and chain assembly back into the t-case directly opposite of how it was removed in step #10.
16. Place the shift rail spring (removed in step 9) over the end of the shift rail.
17. Properly clean the case half mating surfaces with non-petroleum based cleaner (alcohol or brake part cleaner). When dry, apply a 3mm (1/8") bead of high temp. RTV sealer/silicon to the seal surface on the front case half. Be sure the case locating dowels are in place and that the mainshaft splines are engaged in the oil pump's inner gear. Install and tighten the front case (#3) to the rear case (#49) attaching bolts. Torque to 30 ft-lbs.
18. There are two more small snap rings supplied in the kit. Both rings are for the blue, speedometer gear also included with the kit. First, install one of the rings in the lower groove on the main shaft. Slide on the blue speedometer gear until it rests on the lower snap ring. Install the second snap ring onto the shaft just above the plastic gear. Refer to Figure 4 for the locations of snap rings.
19. Press the new output bearing into the new bearing retainer housing.
20. Install the output bearing retainer snap ring on top of the bearing installed in step 19. Check photo on page 1 for proper snap ring installation.
21. Using silicon, lay a small 1/8" bead around the outer edge of seal, and press the new oil seal into the rear bearing retainer housing (see Figure 4).
22. With the gasket surfaces clean, silicon the new rear housing assembly on the rear of the t-case. Use a 3mm (1/8") bead of silicon and torque to 30 ft-lbs.
23. Reinstall the speedometer drive gear assembly into the new rear housing. Rotate the speedometer drive gear insert until proper engagement is achieved.
(Note: There are four different positions - only one will work depending on which drive gear you have.)
24. Install the front and rear output yokes onto the 231J. Tighten the rear output yoke nut to 180 ft. lbs. Fill with automatic transmission fluid (Dexron III).

Figure 4

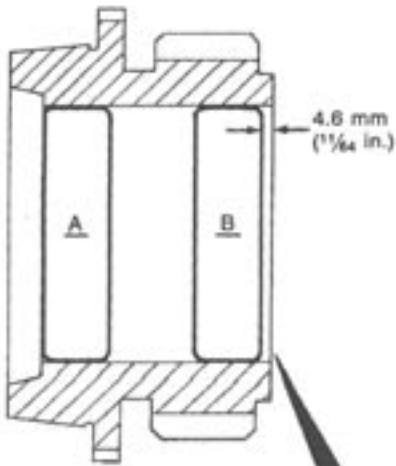
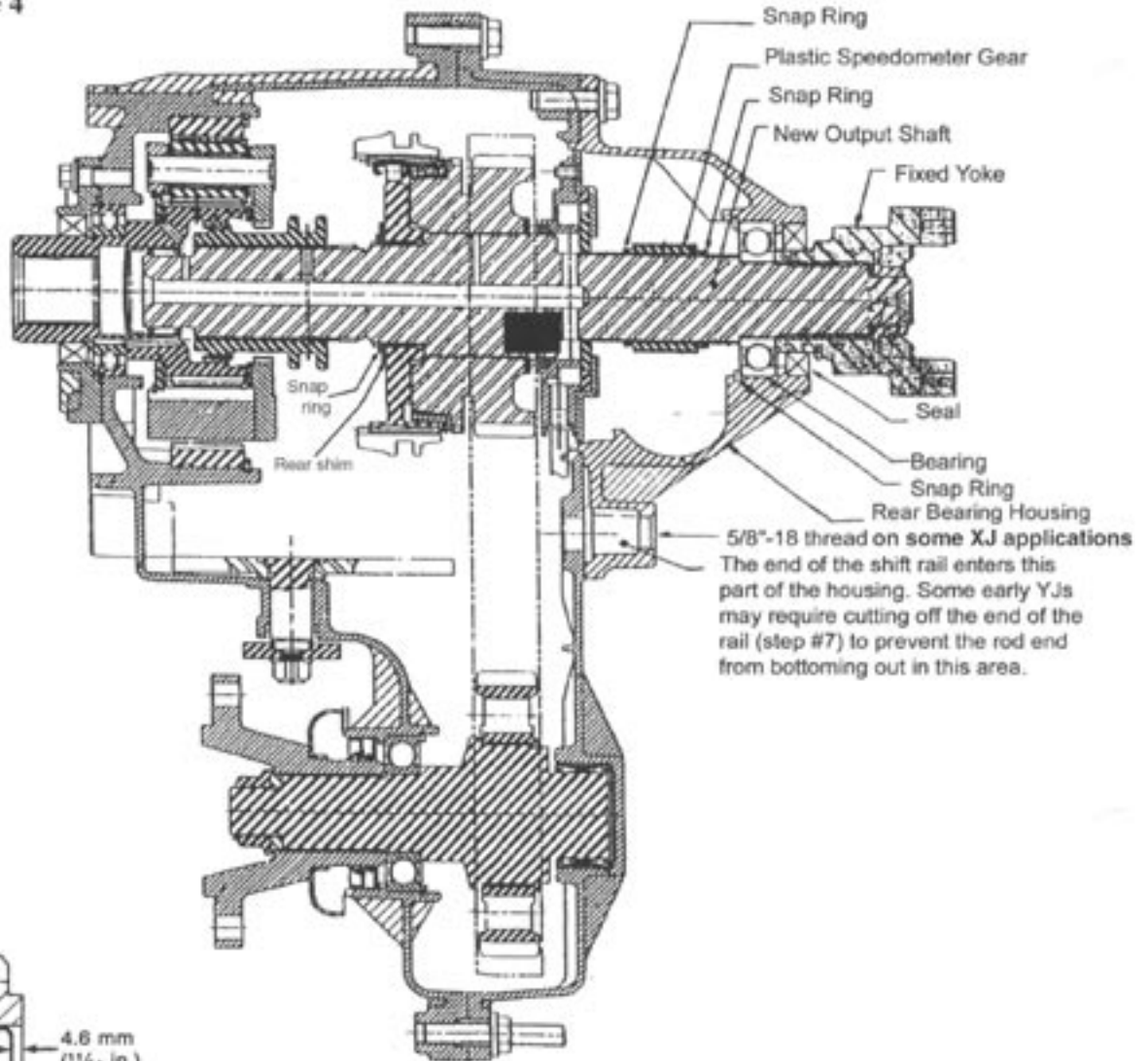

If necessary, remove bearings in the drive sprocket as indicated in the diagram to the left. The diagram to the left is the same as #26 on the exploded view of the 231J transfer case.

A design change by Jeep / New Process in 1997 eliminated the bearings and increased the shaft diameter with improved oiling. Our 231 SS kits use the 2nd generation design.

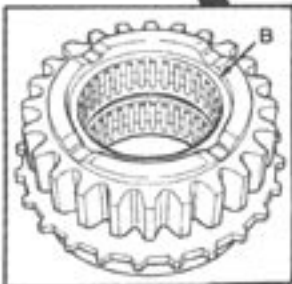

Exploded View of the 231J Transfer Case

○ Included in the Tera Low231 Heavy Duty Short Shaft kit

Note: This diagram shows the Tera Low231 Heavy Duty Short Shaft kit, Tera Low231 4.0:1 case, and the Tera Low2WD kit. A stock setup will appear different than pictured.

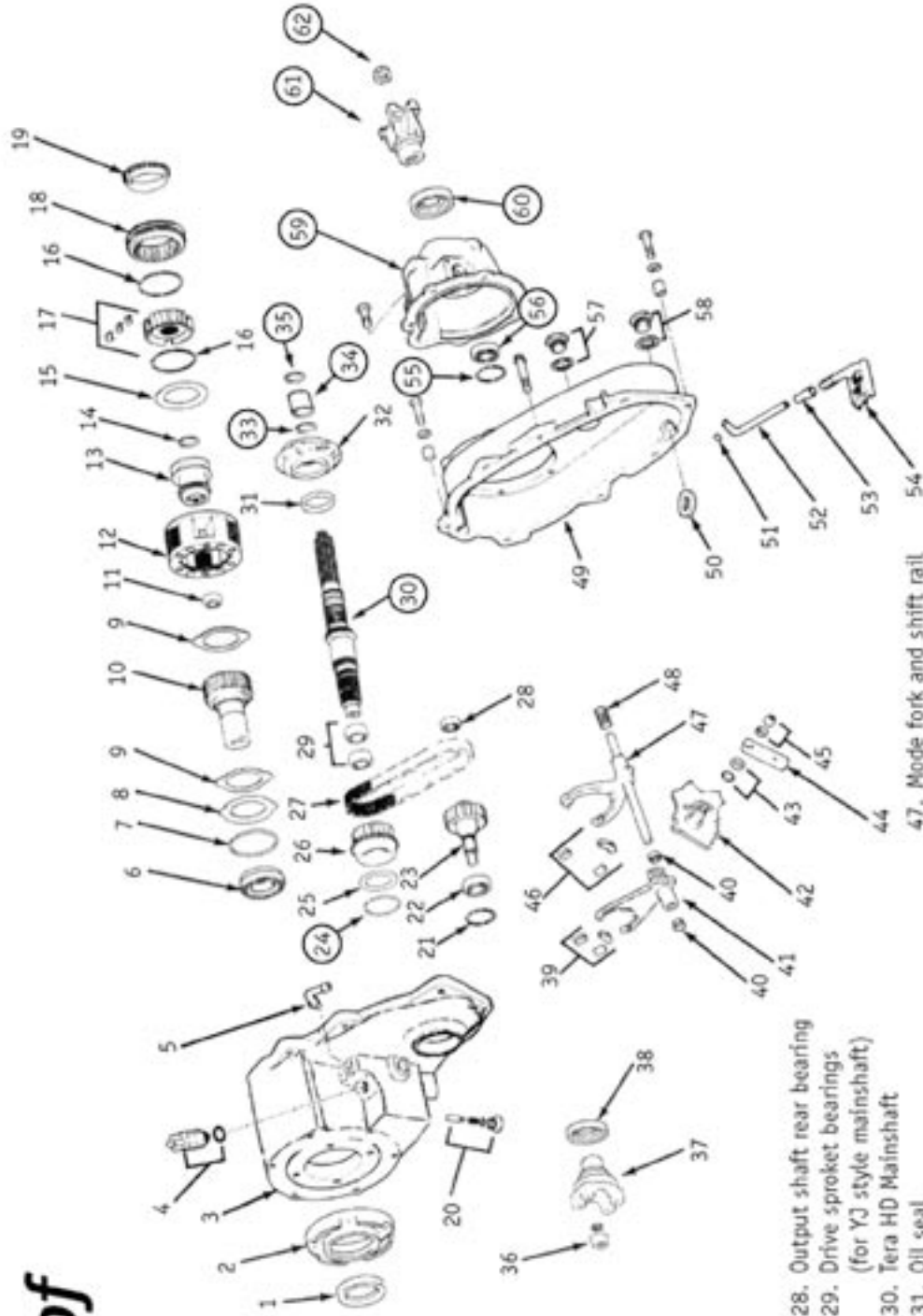

- 1. Front input seal
- 2. Front bearing retainer and seal
- 3. Tera HD Low231 case
- 4. Vacuum switch and seal
- 5. Vent assembly
- 6. Input gear bearing and snap ring
- 7. Low-range gear snap ring
- 8. Input gear retainer
- 9. Low-range gear thrust washer
- 10. Input gear
- 11. Input gear pilot bearing
- 12. Planetary gear assembly
- 13. Range fork shift hub
- 14. Synchro hub snap ring
- 15. Shim
- 16. Synchro hub springs
- 17. Synchro hub and inserts
- 18. Synchro sleeve
- 19. Stop ring
- 20. Shift detent plug, spring, and pin
- 21. Snap ring
- 22. Front output shaft bearing
- 23. Front output shaft
- 24. Large snap ring
- 25. Shim
- 26. Drive sprocket
- 27. Drive chain
- 28. Output shaft rear bearing
- 29. Drive sprocket bearings (for YJ style mainshaft)
- 30. Tera HD Mainshaft
- 31. Oil seal
- 32. Oil pump assembly
- 33. Snap ring
- 34. Speedometer drive gear
- 35. Snap ring
- 36. Front yoke nut
- 37. Front yoke
- 38. Front output seal
- 39. Range fork inserts
- 40. Range fork bushings
- 41. Range fork
- 42. Sector
- 43. O-ring and seal
- 44. Range lever
- 45. Range lever nut and washer
- 46. Mode fork inserts
- 47. Mode fork and shift rail
- 48. Mode spring
- 49. Rear case
- 50. Magnet
- 51. Pickup tube oil ring
- 52. Mode fork inserts
- 53. Tube connector
- 54. Oil pickup screen
- 55. Snap ring
- 56. Rear bearing
- 57. Fill plug and gasket
- 58. Drain plug and gasket
- 59. Rear housing
- 60. Rear output seal
- 61. Rear yoke
- 62. Rear yoke nut



Tera Manufacturing, Inc.
5247 South Commerce Dr.
Murray, Utah 84107
Phone/801.288.2585
Fax/801.713.2313
www.teraflex.biz

Figure 3