

2360 Boswell Road
Chula Vista, CA 91914
Phone 619.216.1444
Fax 619.216.1474
E-Mail tech@explorerprocomp.com

**Latest Revision:
2.24.2012**



PRO COMP SUSPENSION

Suspension Systems that Work!

**Part # 2583
2008-2012 Dodge
2500
Non Y-Style
Dual Steering
Stabilizer Bracket
Kit**

This document contains very important information that includes warranty information and instructions for resolving problems you may encounter. Please keep it in the vehicle as a permanent record.

- ◆ **This installation requires a professional mechanic!**
- ◆ We recommend that you have access to a factory service manual for your vehicle to assist in the disassembly and reassembly of your vehicle. It contains a wealth of detailed information.
- ◆ Prior to installation, carefully inspect the vehicle's steering and driveline systems paying close attention to the tie rod ends, ball joints, wheel bearing preload, pitman and idler arm. Additionally, check steering-to-frame and suspension-to-frame attaching points for stress cracks. The overall vehicle must be in excellent working condition. Repair or replace all worn or damaged parts!
- ◆ Read the instructions carefully and study the illustrations before attempting installation! You may save yourself a lot of extra work.
- ◆ Check the parts and hardware against the parts list to assure that your kit is complete. Separating parts according to the areas where they will be used and placing the hardware with the brackets before you begin will save installation time.
- ◆ Check the special equipment list and ensure the availability of these tools.
- ◆ Secure and properly block vehicle prior to beginning installation.
- ◆ ***ALWAYS*** wear safety glasses when using power tools or working under the vehicle!
- ◆ Use caution when cutting is required under the vehicle. The factory undercoating is flammable. Take appropriate precautions. **Have a fire extinguisher close at hand.**
- ◆ Foot pound torque readings are listed on the Torque Specifications chart at the end of the instructions. These are to be used unless specifically directed otherwise. Apply thread lock retaining compound where specified.
- ◆ *Please note that while every effort is made to ensure that the installation of your Pro Comp lift kit is a positive experience, variations in construction and assembly in the vehicle manufacturing process will virtually ensure that some parts may seem difficult to install. Additionally, the current trend in manufacturing of vehicles results in a frame that is highly flexible and may shift slightly on disassembly prior to installation. The use of pry bars and tapered punches for alignment is considered normal and usually does not indicate a faulty product. However, if you are uncertain about some aspect of the installation process, please feel free to call our tech support department at the number listed on the cover page. We do not recommend that you modify the Pro Comp parts in any way as this will void any warranty expressed or implied by the Pro Comp Suspension company.*

Optional Equipment Available from your Pro Comp Distributor!

56120	Double Shock Hoop Kit
72501B	Traction Bars: Crew Cab
72098B	Traction Bar Mounting Kit: Crew Cab
219838	Dual Steering Stabilizer Kit
50328	U-bolt kit for vehicles w/ Dana 80 rear axle.

Check out our outstanding selection of Pro Comp tires to compliment your new installation!

Part #	Description	Qty.	Illus.	Page
91-5387	CENTER BRACKET	1	2	4
91-5373	TIE ROD BRACKET	2	1	4
90-5391	SPACER: Tie Rod Bracket	1	1	4
020106	HARDWARE PACK: Tie Rod Bracket-3/8" U-Bolt	2	1	4
20108	HARDWARE PACK: Center Bracket-7/16" U-Bolt	2	2	4
90-6401	HARDWARE PACK: Center Bracket	1	-	-
43FNNE8Y	7/16"-20 Gr. 8 NYLOC NUT	4	2	4
43NWHDY/SAE	7/16" SAE Gr. 8 HARDENED WASHERS	4	2	4
90-6253	HARDWARE PACK: Center Bracket	1	-	-
70-0503001800	1/2" X 3" Gr. 8 HEX BOLT	2	3	5
72-050100816	1/2" USS Gr. 8 STOVER NUT	2	3	5
73-05000034	1/2" SAE Gr. 8 HARDENED FLAT WASHER	4	3	5
P-843	SHOCK BOLT	2		
Suggested Steering Stabilizers:				
223500	STEERING STABILIZER X2	2	2,3	4
ZX2904	STEERING STABILIZER X2	2	2,3	4
FX6704	STEERING STABILIZER X2	2	2,3	4

INSTALLATION INSTRUCTIONS:

- Position your vehicle on a smooth, flat, hard surface (i.e. concrete or asphalt). Block the rear tires and set the emergency brake.
- Remove the factory steering stabilizer from the vehicle and discard.
- Center the front wheels under the vehicle. On the driver side, install the tie rod brackets (91-5373) to the tie rod using the supplied 3/8" U-bolts from kit (020106). Install the tie rod bracket outer U-bolt and spacer (90-5391) on the machined surface of the tie rod next to the outer tie rod threads. See ILLUSTRATION 1A.
NOTE: Be sure the brackets are facing toward the front of the vehicle. Also be sure the angled side of the bracket is facing toward the center of the truck.
- On the passenger side, install the tie rod brackets (91-5373) to the tie rod using the supplied 3/8" U-bolts from kit (020106). Measure out 5" from the step in the tie rod

to the inside U-bolt and secure the tie rod bracket (91-5373). See ILLUSTRATION 1B.

NOTE: Be sure the brackets are facing toward the front of the vehicle. Also be sure the angled side of the bracket is facing toward the center of the truck.

- Install the center bracket (91-5387) to the pass side of the axle using 7/16" U-bolts and hardware as shown in ILLUSTRATION 2.

NOTE: The inner U-bolt should be 3/8" from the passenger side edge of the differential center section.

NOTE: Additional adjustments of these brackets may be necessary.

- Insert the body ends of the steering stabilizers, to the center bracket (91-5387) using the supplied 1/2" X 3" shock bolts and hardware. See ILLUSTRATION 3.

NOTE: Remove the 1/2" Sleeve from the shaft end bushing.

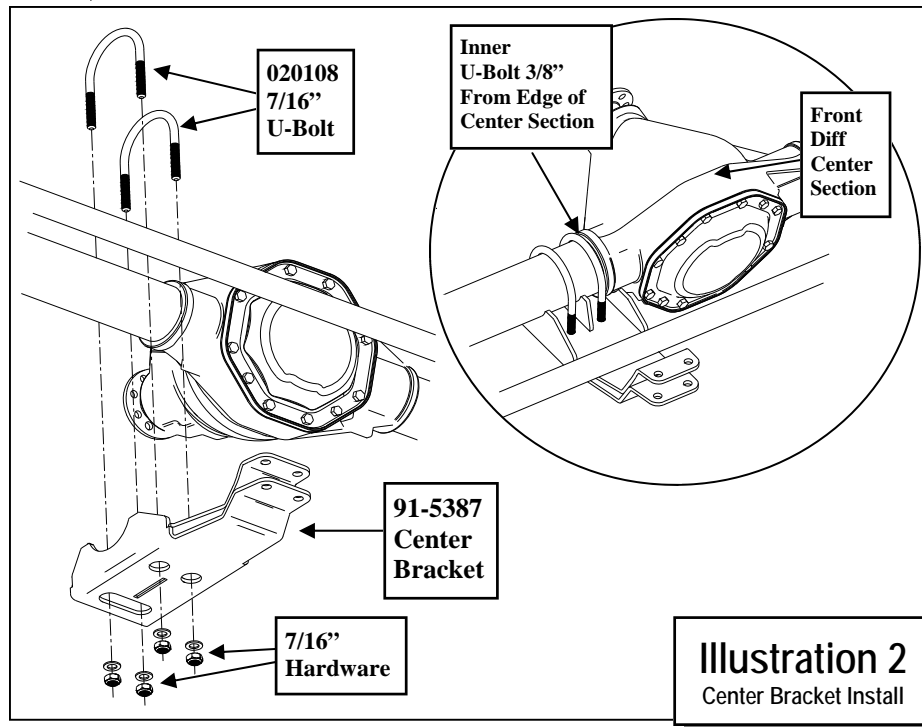
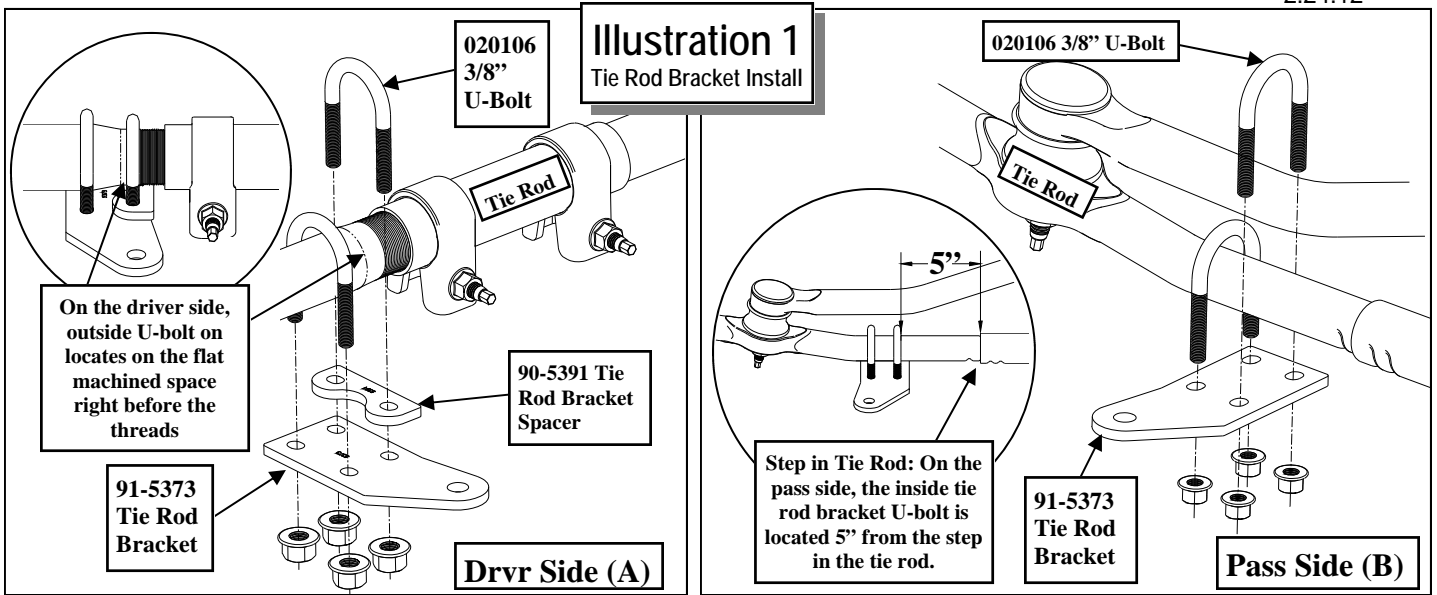

7. Bolt the shaft ends of the stabilizers to the tie rod mounting brackets using the supplied shock bolts (**P- 843 with the heads up**), 3/8" thick spacers (**45281**) and 1/2" hardware. See ILLUSTRATION 3. Torque the 5/8" mounting bolt hardware according to the torque chart below.
8. Cycle the steering full left and full right to assure there are no binding, clearance issues or bottoming out and/or over extension of the stabilizers.

NOTE: The steering should hit the

stops before the shocks bottom out in full compression. There should be 1/8" of shock shaft visible in that position.

9. If necessary, readjust the brackets. Torque the U-bolt hardware according to the chart on page 5 to prevent the brackets from moving.
10. Re-torque all the newly installed hardware after 100 miles or any off road use.

Illustration 3
 Steering Stabilizer
 Install

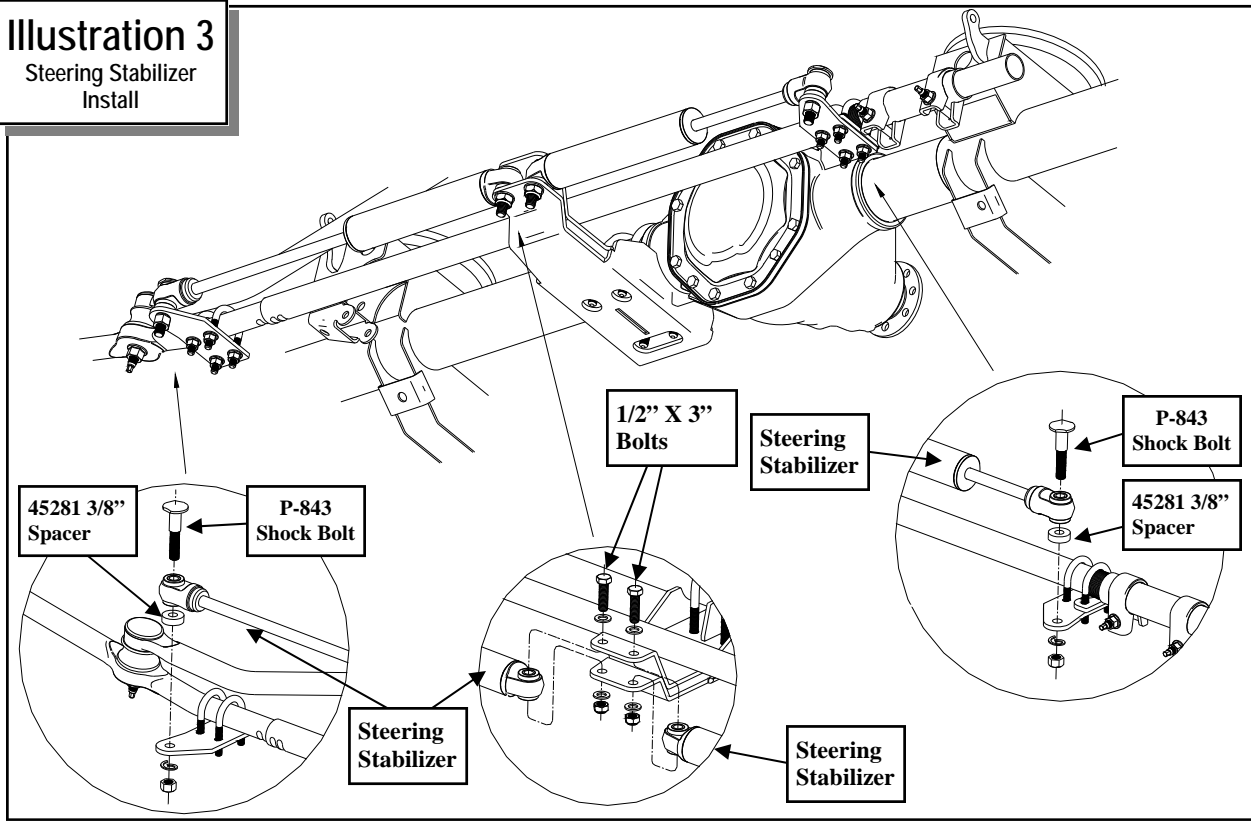

Use this only as a guide for hardware without a called out torque specification in the instruction manual.

Bolt Torque and ID						
Decimal System			Metric System			
All Torques in Ft. Lbs. Maximums						
Bolt Size	Grade 5	Grade 8	Bolt Size	Class 9.8	Class 10.9	Class 12.9
5/16	15	20	M6	5	9	12
3/8	30	45	M8	18	23	27
7/16	45	60	M10	32	45	50
1/2	65	90	M12	55	75	90
9/16	95	130	M14	85	120	145
5/8	135	175	M16	130	165	210
3/4	185	280	M18	170	240	290

<p>1/2-13x1.75 HHCS</p> <p>D T L X</p>	<p>Grade 5 Grade 8</p> <p>(No. of Marks + 2)</p>	<p>M12-1.25x50 HHCS</p> <p>D T L X</p>
--	--	--

<p>G = Grade (Bolt Strength)</p> <p>D = Nominal Diameter (Inches)</p> <p>T = Thread Count (Threads per Inch)</p> <p>L = Length (Inches)</p> <p>X = Description (Hex Head Cap Screw)</p>	<p>P = Property Class (Bolt Strength)</p> <p>D = Nominal Diameter (Millimeters)</p> <p>T = Thread Pitch (Thread Width, mm)</p> <p>L = Length (Millimeters)</p> <p>X = Description (Hex Head Cap Screw)</p>
---	--

Notice to Owner operator, Dealer and Installer:

Vehicles that have been enhanced for off-road performance often have unique handling characteristics due to the higher center of gravity and larger tires. This vehicle may handle, react and stop differently than many passenger cars or unmodified vehicles, both on and off-road. You must drive your vehicle safely! Extreme care should always be taken to prevent vehicle rollover or loss of control, which can result in serious injury or even death. Always avoid sudden sharp turns or abrupt maneuvers and allow more time and distance for braking! Pro Comp reminds you to fasten your seat belts at all times and reduce speed! We will gladly answer any questions concerning the design, function, maintenance and correct use of our products.

Please make sure your Dealer/Installer explains and delivers all warning notices, warranty forms and instruction sheets included with Pro Comp product.

Application listings in this catalog have been carefully fit checked for each model and year denoted. However, Pro Comp reserves the right to update as necessary, without notice, and will not be held responsible for misprints, changes or variations made by vehicle manufacturers. Please call when in question regarding new model year, vehicles not listed by specific body or chassis styles or vehicles not originally distributed in the USA.

Please note that certain mechanical aspects of any suspension lift product may accelerate ordinary wear of original equipment components. Further, installation of certain Pro Comp products may void the vehicle’s factory warranty as it pertains to certain covered parts; it is the consumer’s responsibility to check with their local dealer for warranty coverage before installation of the lift.

Warranty and Return policy:

Pro Comp warranties its full line of products to be free from defects in workmanship and materials. Pro Comp’s obligation under this warranty is limited to repair or replacement, at Pro Comp’s option, of the defective product. Any and all costs of removal, installation, freight or incidental or consequential damages are expressly excluded from this warranty. Pro Comp is not responsible for damages and / or warranty of other vehicle parts related or non-related to the installation of Pro Comp product. A consumer who makes the decision to modify his vehicle with aftermarket components of any kind will assume all risk and responsibility for potential damages incurred as a result of their chosen modifications. Warranty coverage does not include consumer opinions regarding ride comfort, fitment and design. Warranty claims can be made directly with Pro Comp or at any factory authorized Pro Comp dealer.

IMPORTANT! To validate the warranty on this purchase please be sure to mail in the warranty card.

Claims not covered under warranty-

- Parts subject to normal wear, this includes bushings, bump stops, ball joints, tie rod ends and heim joints
 - Discontinued products at Pro Comp’s discretion
- Bent or dented product
- Finish after 90 days
- Leaf or coil springs used without proper bump stops
- Light bulbs
- Products with evident damage caused by abrasion or contact with other items
- Damage caused as a result of not following recommendations or requirements called out in the installation manuals
- Products used in applications other than listed in Pro Comp’s catalog
- Components or accessories used in conjunction with other manufacturer’s systems
- Tire & Wheel Warranty as per Pro Competition Tire Company policy
- Warranty claims without “Proof of Purchase”
- Pro Comp Pro Runner coil over shocks are considered a serviceable shock with a one-year warranty against leakage only. Rebuild service and replacement parts will be available and sold separately by Pro Comp. Contact Pro Comp for specific service charges.
- Pro Comp accepts no responsibility for any altered product, improper installation, lack of or improper maintenance, or improper use of our products.

E-Mail: tech@explorerprocomp.com
Website: www.explorerprocomp.com
Fax: (619) 216-1474
Ph: (619) 216-1444

PLACE
WARRANTY REGISTRATION
NUMBER
HERE: _____