

4X4 ACCESSORIES

PORTABLE COMPRESSOR KIT

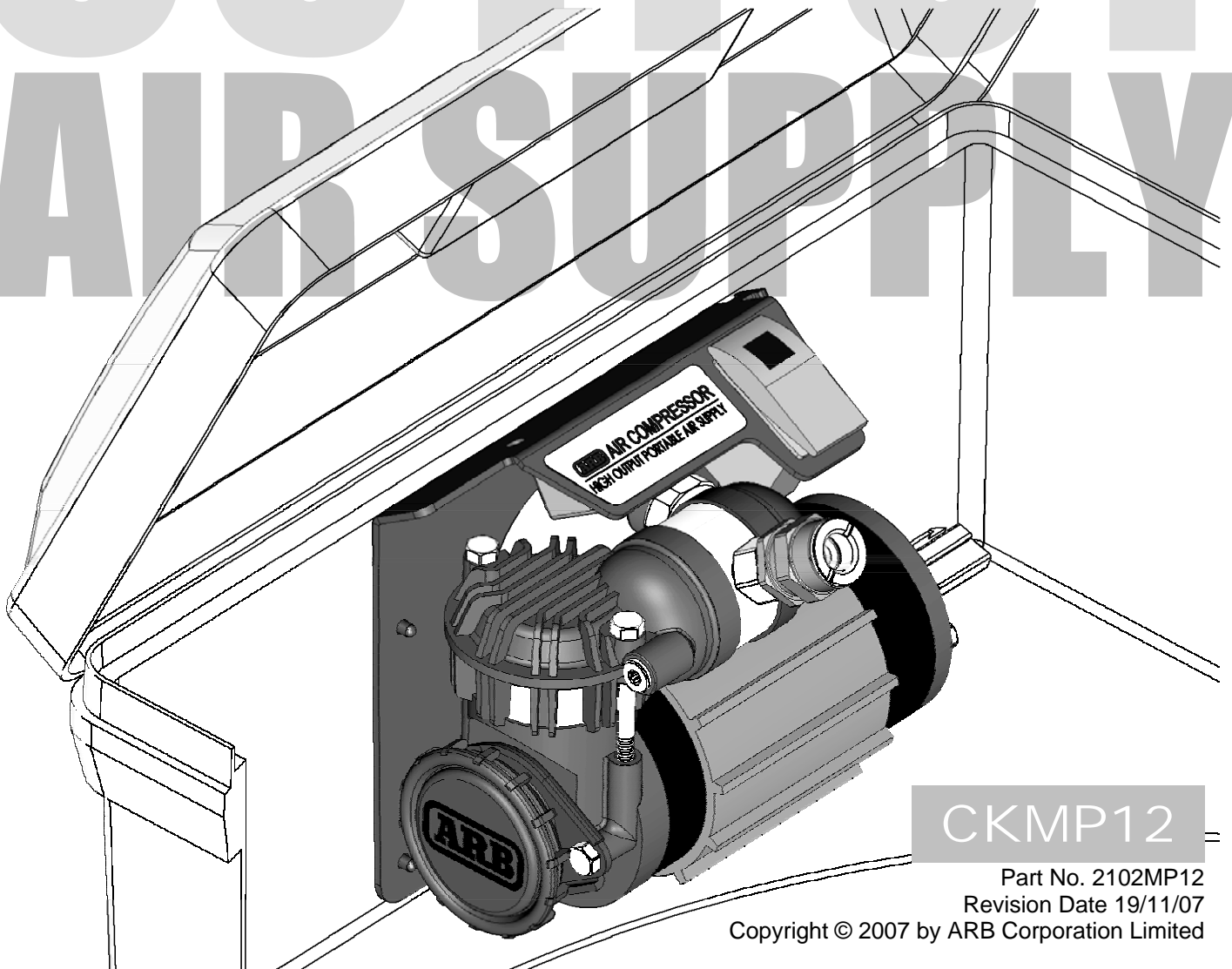

CKMP12

Part No. 2102MP12

Revision Date 19/11/07

Copyright © 2007 by ARB Corporation Limited

No liability is assumed for damages resulting in the use of the information contained herein.
ARB Air Locker Air Operated Locking Differentials, ARB Air Locker Air Activation System
and Air Locker are trademarks of ARB Corporation Limited.
Other product names used herein are for identification purposes only and may be trademarks of their respective owners.

ARB 4x4 ACCESSORIES

Corporate Head Office

**42-44 Garden St
Kilsyth, Victoria
AUSTRALIA
3137**

**Tel: +61 (3) 9761 6622
Fax: +61 (3) 9761 6807**

**Australian enquiries
North and South American enquiries
Other international enquiries**

**sales@arb.com.au
sales@arbusa.com
exports@arb.com.au**

www.arb.com.au

Table of Contents :

1 Introduction	2
1.1 What Is Included	2
1.2 Features & Specifications	3
1.3 Optional Extras For Your Compressor	4
2 Safe Air Compressor Operation	5
2.1 Connecting for Use	5
2.2 Safety Precautions	6
2.3 Tyre Filling	7
2.4 Understanding The Built-In Protection Devices	8
3 Service & Maintenance	9
3.1 Air Filter Service	9
3.2 Electrical Fuse Replacement	10
3.3 Safety Valve Service	10
4 Parts List	11
4.1 Exploded Diagram	11
4.2 Itemized Parts List	12



1 Introduction

IMPORTANT :

To get the safest and most effective service from this portable air compressor, please read this guide in its entirety before attempting actual use.

HINT : Place a ✓ mark inside each of the symbols as you follow each step so that you don't miss any.

1.1 What Is Included

Below is a detailed list of items included with this kit:

- Fully assembled and performance tested air compressor mounted into a quality tradesman grade hard case.
- OEM quality illuminated compressor isolating switch.
- High quality wiring loom with automotive grade alligator clamp type battery contacts, and a pressure switch driven automotive relay control circuit.
- Splash resistant air filter with washable high-flow sintered bronze filter cartridge.
- 6 meter [20 ft] long high quality abrasion and heat resistant air hose with male to female couplings.
- Hose couplings are specially designed corrosion resistant, one-handed (push-lock) quick connect type to suit US industrial standard air fittings (Ref: compatible types Section 1.3).
- Inflation accessories kit including high-flow tyre filler attachment (US industrial standard) with integral stop-valve, a Schrader valve to US industrial standard adaptor, and extra nozzle attachments for inflating items such as sports balls, air mattresses, etc.

1 Introduction

1.2 Features of the CKMP12 Portable Compressor

The ARB CKMP series portable air compressor is a world class recreational product designed and built to commercial / industrial standards boasting the following features:

- Ultra compact design makes this the highest flowing portable compressor in its class.
- Constructed entirely of light weight, high strength engineering grade materials, including military and aerospace standard components.
- Fully sealed components for moisture and dust resistance.
- Motor is 100% ball bearing equipped, and features a unique linear brush pre-load system for extra long life, low heat and quiet operation throughout the life of the unit.
- Motor is thermal cut-out protected against damage caused by extreme temperature use.
- Pressure switch and 40 amp automotive relay equipped electrical system prevents run-on when not filling, or any damage to compressor or hoses as a result of the pressure generated from a kinked air line.
- Illuminated isolating switch is easy to see at night, and protects the user from hazardous sparking when connecting the alligator clips to the battery terminals.
- Heavy duty Maxi-Fuse equipped power leads for professional in-line circuit protection.
- Hard-anodized cylinder bore and PTFE (Teflon) impregnated carbon fiber piston seal for reduced friction and maximum trouble free life.
- Compressor piston is equipped with a German made high shock rated cylindrical roller bearing.
- High density and high flow washable sintered bronze air filter element.
- Over-pressure safety valve equipped as a back-up protection from either pressure switch failure, thermal over pressure generated in a hot vehicle (i.e., no need to drain pressure when finished use.), or accidental connection to an external high pressure source.

1 Introduction

1.3 Specifications of CKMP12 Compressor

GENERAL SPECS		METRIC		IMPERIAL	
SUPPLY VOLTAGE	12	Volts DC	12	Volts DC	
MAX CURRENT DRAW	32	Amps @ 690 KPa	32	Amps @ 100 PSI	
FUSE RATING (Maxi-Blade type)	40	Amps	40	Amps	
RELAY RATING	40	Amps	40	Amps	
WEIGHT (total kit)	6.5	Kgs	14.3	Lbs	
DIMENSIONS	-LENGTH	440 mm	17.32	inches	
	-WIDTH	238 mm	9.37	inches	
	-HEIGHT	208 mm	8.19	inches	
DUTY CYCLE @ 22°C [72°F]	50	%	30	mins. per hour	
PRESSURE SWITCH CLOSED	< 520	KPa	< 75	PSI	
PRESSURE SWITCH OPEN	> 725	KPa	> 105	PSI	
SAFETY VALVE PRESSURE	> 1035	KPa	> 150	PSI	
MOTOR THERMAL CUT-OUT	115	degrees C	239	degrees F	
MAX. AMBIENT TEMPERATURE	100	degrees C	212	degrees F	

NO LOAD SPECS		METRIC @ 0 KPa		IMPERIAL @ 0 PSI	
CURRENT DRAW	13	Amps	13	Amps	
AIR FLOW RATE	75.1	L/min.	2.65	CFM	

SPECS @ TYRE PRESSURE		METRIC @ 200 KPa		IMPERIAL @ 29 PSI	
CURRENT DRAW	22.9	Amps	22.9	Amps	
AIR FLOW RATE	61.6	L/min.	2.18	CFM	

EXTERNAL CONNECTIONS SPECS	
AIR INTAKE THREAD (female)	1/4-18 NPSC (parallel pipe thread)
AIR FILTER THREAD (male)	1/4-18 NPT (tapered pipe thread)
PRESSURE SWITCH THREAD	1/4-18 NPT (tapered pipe thread)
SAFETY VALVE PORT THREAD	1/8 BSPP (parallel pipe thread)
MANIFOLD THREAD	1/4-18 NPT (tapered pipe thread)
AIR COUPLING FITTING TYPE (international equivalent standards)	'US Industrial Standard' ISO 6150 B Rectus series 23/24/1400 Tema series 1400 Legris series 23 DYNAQUIP D3 CEJN 310 US.MIL.C 4109 Norma / AFNOR: NF.E49.053 Parker series 30-1/4" and 20-1/4" Aignep 220 Hansen series 3000 Norgren series 237 Gromelle series 600

WARRANTY

This ARB Air Compressor is designed to provide many years of trouble free recreational use, and is warranted to be free from manufacturing defects for two (2) years from the date of purchase.

NOTE : The specifications above were recorded under laboratory conditions at 22°C [72°F].



2 Safe Air Compressor Operation

2.1 Connecting For Use

- Position the compressor on a sturdy flat surface before opening the box.
- Unlock and open the box using the two toggle clamps.
- Make sure that the switch is in the 'OFF' position by pressing down on the top of the switch rocker.

NOTE : The switch should normally already be in the 'OFF' position as it is designed to be moved into the 'OFF' position every time the box lid is closed.

- Uncoil the power lead and connect the positive (+) alligator clamp (RED handle) directly to the positive (+) terminal of the vehicle's 12 volt battery.
- Connect the negative (-) alligator clamp (BLACK handle) directly to the negative (-) terminal of the vehicle's 12 volt battery.

NOTE : The switch should now be illuminated but the compressor will not start until the switch rocker is pressed on the bottom. This tells you the compressor has now been connected to power.

- Attach the air hose to the compressor by inserting the male end of the hose into the hose coupling on the compressor and simply pressing inward until the coupling sleeve clicks forward. The sleeve of the coupling does not need to be pulled back by hand at all.
- Attach the tyre filler (or other compatible device) to the opposite end of the hose in the same way.
- Press the bottom of the rocker switch down to start the compressor and pressurize the manifold and hose.

NOTE : Once compressed air has expelled through the attached device (e.g., tyre filler, air tool, etc.) the compressor should automatically start running. It will continue to run until air use has stopped and the pressure in the manifold and hose reaches the pre-set pressure switch cut-out level.

3 Service & Maintenance

2.2 Safety Precautions

Please carefully read and always abide by each of the following points when using a portable air compressor.

- Never make connections to the battery with the isolating switch turned 'ON' as the resulting sparking at the battery terminals could pose a fire hazard.
- Never attempt to stop or slow the flow of compressed air using direct exposure to skin.

NOTE : Normal textile clothing does not protect the skin against the risk of air embolism posed by exposure to compressed air.

NOTE : An air embolism is a serious condition of the blood stream which may result in severe injury or death.

- For the same reason as above, never use compressed air to clean clothing, hair or body.
- Wear suitable protective equipment (e.g., glasses, face shields, etc.) to control the risk of injury due to projectile particles.
- Never point the hose at anyone and always see that bystanders are out of the line of air flow.
- If using extension or replacement hoses other than genuine ARB hoses, use only sound strong hose with secure couplings and connections having a high temperature rating and a burst pressure of over 1380 Kpa [200 PSI].
- If using compressed air accessories (e.g., extension or replacement hoses, or pneumatic devices like air tools) other than genuine ARB, avoid the danger of spontaneous disconnection by using only products with hose fittings that conform to one of the international standards listed in the specifications (ref: Section 1.3).
- Air hoses should be securely held to prevent whipping.
- Compressed air contains contaminants which makes it unsuitable for use in air-supplied respiratory protective devices such as spray painting hoods. Only use compressed air with such devices when appropriately filtered through approved filtration equipment.

3 Service & Maintenance

2.3 Tyre Filling

- Connect the compressor to the vehicle's battery or other 12V DC power supply as in Section 2.1.

NOTE : If the vehicle is in a well ventilated area, leaving the vehicle running at idle while running the compressor will give maximum compressor performance and avoid depleting your vehicle's battery.

- Attach the tyre filler (supplied) to the air hose coupling by inserting the male end of the filler into the hose coupling and simply pressing inward until the coupling sleeve clicks forward. The sleeve of the coupling does not need to be pulled back by hand at all.

- Press the bottom of the rocker switch down to start and pressurize the compressor.

NOTE : ARB's tyre filler attachment is equipped with a stop valve. Air will not pass through the tyre filler attachment until it is connected to a tyre valve.

- Attach the tyre filler attachment to any standard tyre valve by depressing the latch lever of the filler and then pushing the filler onto the tyre valve until a good seal is made.

NOTE : The compressor should automatically start now once air passes through the filler.

- To keep air flowing without holding the filler simply release the lever on the filler while still holding the filler onto the tyre valve and let go of the filler.

- To stop filling and remove the filler from the valve depress the lever on the filler and pull the filler away from the tyre valve.

NOTE : Periodically disconnect the filler and check the tyre pressure with an automotive tyre pressure gauge.

IMPORTANT :

Do not fill your tyres over the manufacturer's specified maximum pressure rating.

- To protect the tyre valve, always refit the tyre valve cap once you have inflated your tyres to the desired pressure.

3 Service & Maintenance

2.4 Understanding The Built-In Protection Devices

This compressor has been equipped with both THERMAL and OVER PRESSURE protection devices in the interests of personal safety and to protect the unit from unnecessary internal damage.

NOTE : Never disable or modify any of the compressor's built-in protection devices.

2.4.1 Thermal Cutout Switch

The process of compressing air is a natural generator of heat. This heat generation is increased accordingly by increasing the compressed air flow rate or increasing the pressure level of the air flow.

The large DC electric motor inside the compressor is also a source of heat which increases with the amount of work being done by it.

The compressor has been designed to naturally disperse this heat into the air around it, however, the ambient temperature outside will have an effect on how fast this heat can be dispersed. If excessive levels of heat are allowed to build up inside the compressor the unit may be put at risk of internal damage. For this reason an internal electric switch has been designed into the back of the motor which will simply turn the compressor off if the temperature approaches a dangerous level, and will automatically reset and turn the compressor back on once the unit has cooled down to a safe temperature. This off time may last anywhere from just a few minutes up to half an hour depending on conditions around the compressor.

2.4.2 Over Pressure Safety Valve

This compressor is equipped with a pressure operated electric switch which has been factory set to turn off the compressor at a safe level of pressure, and then turn it back on again once the pressure has been exhausted down to a lower level. Should this switch fail for any reason the compressor may generate pressure well beyond its safe shut off limit.

A compressor which has reached its safe pressure maximum that has been left in direct sun or inside a hot vehicle may build up additional pressure past the safe working level.

Connecting your compressor up to any air system which might already contain a residual pressure that is higher than the compressor's safe pressure limit may raise the internal pressure of the compressor past the safe pressure limit.

This compressor is equipped with a mechanical over pressure safety valve which has been factory set to bleed off to atmosphere any excessive pressure build up (i.e., from any of the situations above) before it can pose any personal danger or cause damage to compressor components.

3 Service & Maintenance

3.1 Air Filter Service

The CKMP12 Portable Air Compressor comes factory fitted with a high density, high flow, sintered bronze air filter to protect the compressor components, and any accessories that might be used with the compressor, from damage caused by the ingress of dirt and fine dust particles. The filter element is removable and cleanable and should provide for years of continuous service.

Follow the steps below to disassemble, clean and re-assemble the air filter.

- Unsnap and remove the air filter cover from the air filter base by applying slight prying pressure under the fingers of the cover.
- Remove the filter element disk.
- Vigorously wash the element in a solution of hot soapy water.
- Rinse the element in pure hot water.
- Dry thoroughly.
- Insert the element back into the air filter base making sure that the flattest face of the disk faces toward the compressor.
- Snap the air filter cover back onto the base and rotate the cover into the desired position.

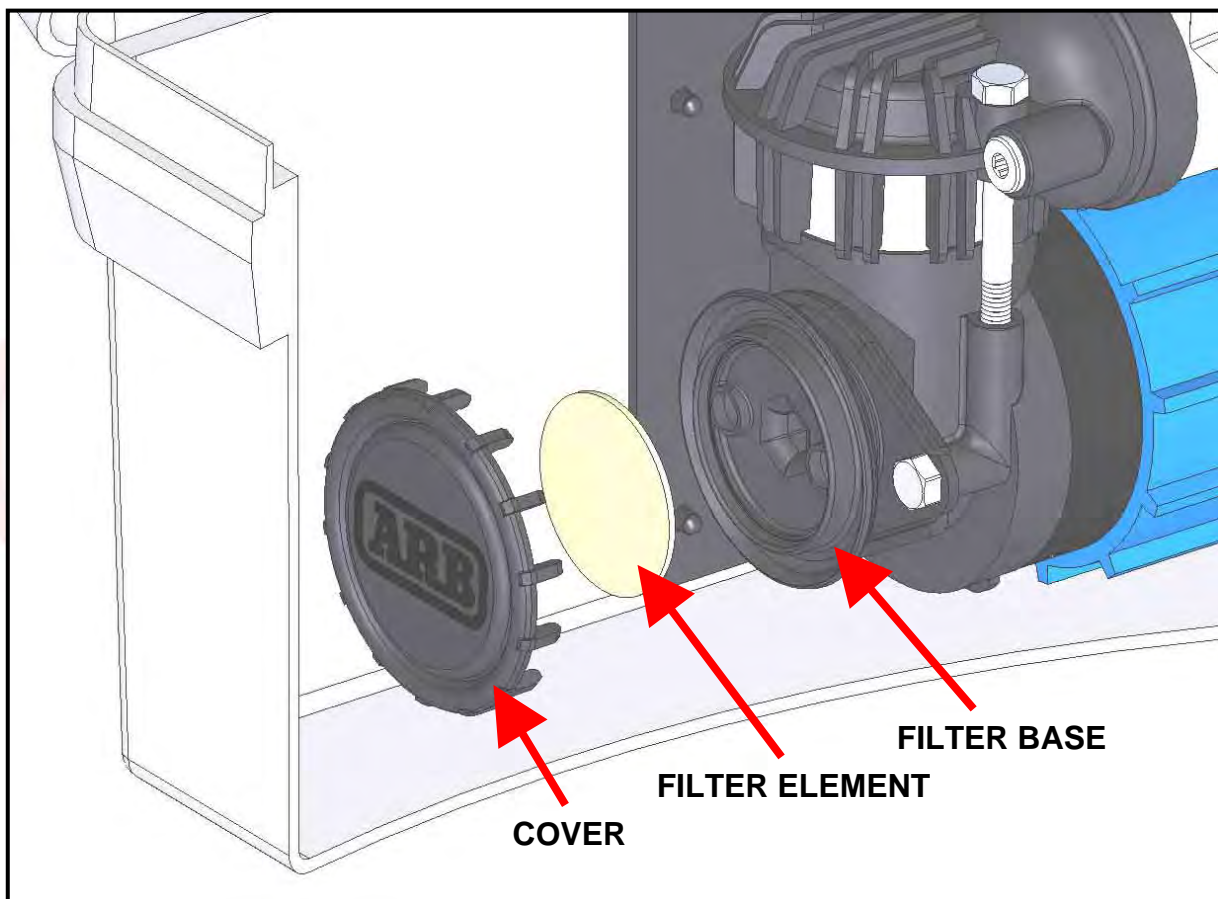

3 Service & Maintenance

3.2 Electrical Fuse Replacement

If the electrical fuse that is equipped inline with the positive (+) power lead (RED) requires replacing, it can be removed by opening the black rubber fuse housing cover and pulling straight outward on the fuse until it slides free of the fuse block. This fuse should only be replaced with a fuse of the same type (maxi blade type) and of the same amp rating or less.

- Unsnap and remove the air filter cover from the air filter base by applying slight prying pressure under the fingers of the cover.

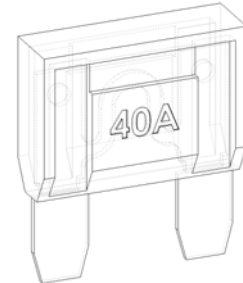

3.3 Safety Valve Service

The CKMP12 Portable Air Compressor comes factory equipped with a safety valve to automatically and safely relieve any excessive pressure from inside the system. This pressure could occur as a result of a fault in the pressure switch circuit, pressure generated from prolonged exposure to direct sunlight, accidental connection to a higher source of pressure, etc. If it becomes necessary to service this valve to change the relief pressure (i.e., use alternate spring) or clean the valve seat then it can be easily disassembled as follows.

- Using a 4mm hex key, unscrew the safety valve fitting from its socket.
- Remove the spring and poppet from inside the valve socket.
- Clean or replace the valve components as required.

NOTE : Replacing safety valve parts with non-genuine ARB parts or modifying these parts in any way could change the relief pressure value, and is therefore not recommended.

- Reassemble safety valve as below and tighten the fitting until the head of the fitting contacts the compressor head casting.

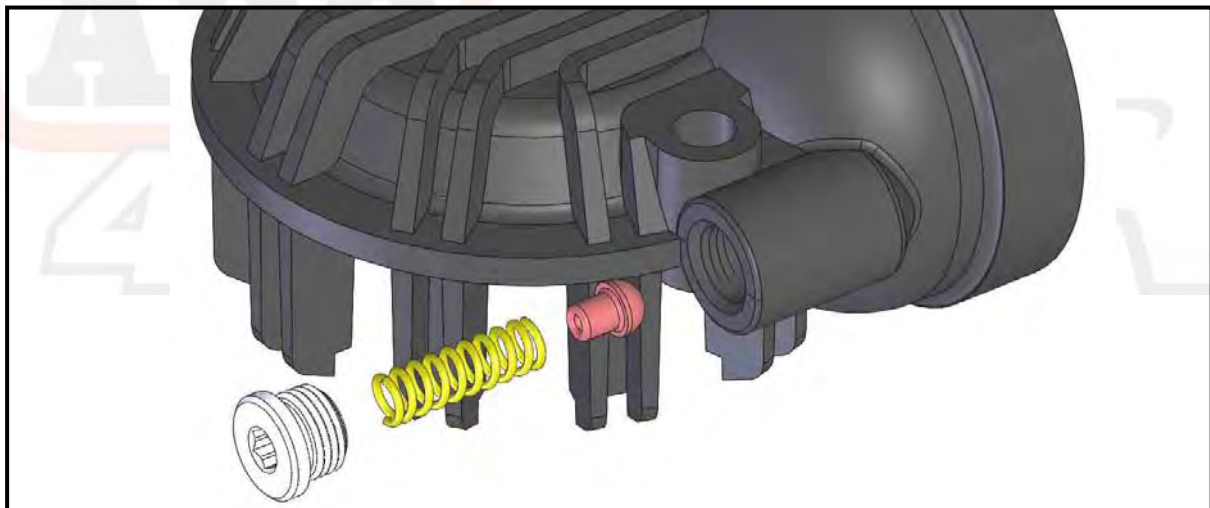

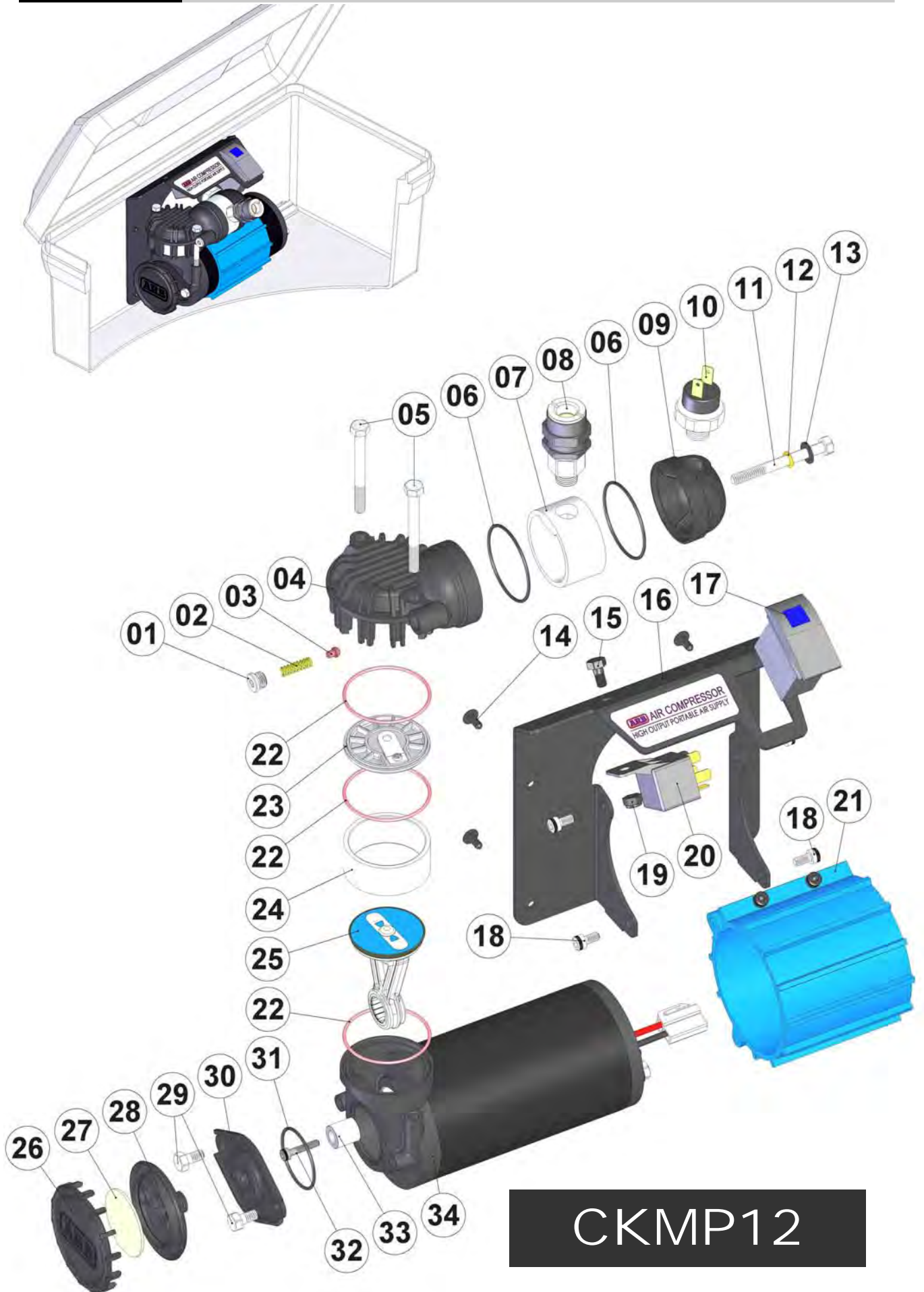

CKMP12



CKMP12

Portable Compressor Kit

ITEM #	QTY	DESCRIPTION	PART #	NOTES
01	1	SAFETY VALVE FITTING	320204	1
02	1	SAFETY VALVE SPRING	150115	1
03	1	SAFETY VALVE POPPET	320205	1
04	1	HEAD ASSEMBLY	320102	1
05	2	BOLT (M6 x 60mm)	200703	
06	2	O-RING (BS031N70)	160241	2
07	1	MANIFOLD TUBE (1/4" NPT)	320224	
08	1	HOSE COUPLING (US STD FEMALE)	171402	
09	1	MANIFOLD CAP (1/4" NPT)	320214	
10	1	PRESSURE SWITCH (1/4" NPT)	CO35	
11	1	BOLT (M6 x 60mm)	200703	
12	1	O-RING (BS010V75)	160242	2
13	1	FLAT WASHER	6151046	
14	4	RIVET (3/16" x 1/2")	6602003	
15	1	BOLT (M6 x 20mm)	6151213	
16	1	MOUNTING BRACKET	320223	
17	1	SWITCH (12V)	180209	
	1	SWITCH COVER ('ARB Compressor')	180212	
18	4	CAP SCREW (M5 x 10mm)	200710	
19	1	NYLON LOCK-NUT (M6)	6151223	
20	1	RELAY (12V,40A)	CO42	
21	1	MOUNT BODY ASSEMBLY	320101	
22	3	O-RING (BS032S70)	160247	2
23	1	VALVE PLATE ASSEMBLY	320105	
24	1	BARREL	320201	
25	1	PISTON ASSEMBLY (SERVICE KIT)	320302	3
26	1	AIR FILTER COVER	320501A	4
27	1	AIR FILTER ELEMENT (DISK TYPE)	290503	4
28	1	AIR FILTER BASE	320501B	4
29	2	BOLT (M6 x 12mm)	200702	
30	1	AIR FILTER FLANGE (1/4" NPT)	320212	
31	1	O-RING (BS028N70)	160243	2
32	1	CAP SCREW (M4 x 20mm)	200708	3,5
33	1	AXLE	320203	3
34	1	MOTOR ASSEMBLY (12V)	320104	
*	1	CARRY CASE	270103	
*	1	INFLATION ACCESSORY KIT (US STD)	171303	
*	1	HOSE ASSEMBLY (US STD)	171301	
*	1	WIRING LOOM (CKMP12)	180410	

* Not illustrated in exploded view.

Specs:

Voltage	12 Volts
Current Draw	No-Load 13A Load 23A
Air Flow	75.1L/min @ 0kPa [2.65CFM @ 0psi] 61.6L/min @ 200kPa [2.18CFM @ 29psi]
Total Weight	6.5kg [14.3lbs]
Size	208mm x 440mm x 238mm (H,L,W) [8.19" x 17.32" x 9.37"]
Manifold Port	1/4" NPT [Pressure Switch] x 1
Pressure Switch	Open 690kPa [100psi] Closed 490kPa [70psi]
Safety Valve	OPEN @ > -1250Kpa [180 PSI]

Notes:

- 1 HEAD ASSY (04) comes pre-assembled with safety valve.
- 2 Complete set of O-ring seals is also available as O-ring Service Kit #320301.
- 3 PISTON ASSEMBLY (25) comes only as a service kit also containing the BARREL (24), AXLE (33), and CAP SCREW (32).
- 4 AIR FILTER BASE (31) & COVER (33) available only in AIR FILTER ASSY #320501 which also includes the element.
- 5 Thread lock must be applied to threads of CAP SCREW (32) and then torqued to 6 Nm [4.4 ft-lb]. CAP SCREW (32) should never be re-used once it has been fully torqued once.

