

Please read these instructions completely before proceeding with installation

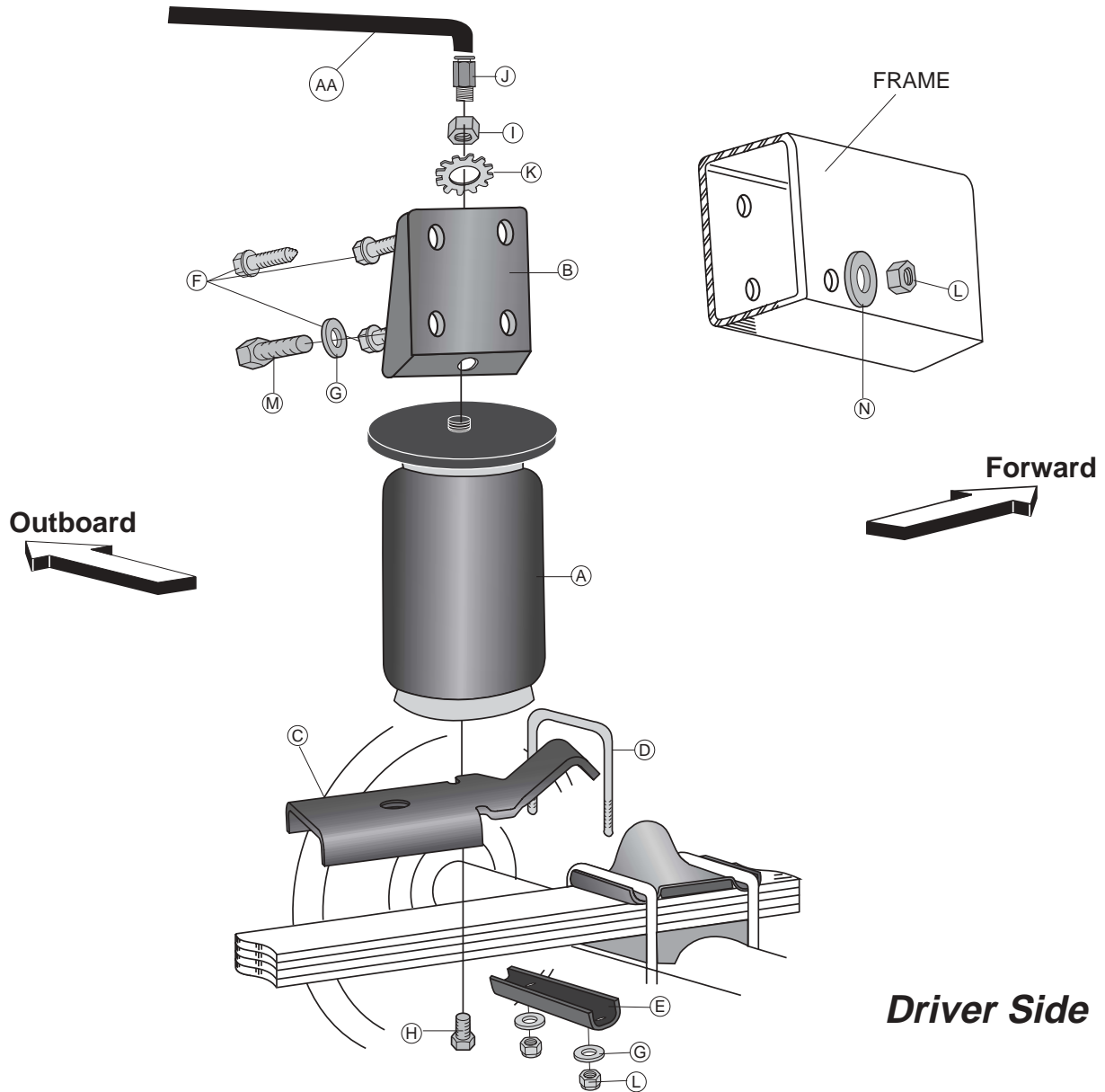

Figure 1

### Ride Control Kit Parts List

Item	Description	Quantity	Item	Description	Quantity
A	Air Sleeve	2	L	3/8"-16 Nyloc Nut	6
B	Upper Bracket	2	M	3/8"-16 Bolt	2
C	Lower Bracket	2	N	3/8" Large Flat Washer	2
D	U-Bolt	2	AA	Air Line Assembly	1
E	Lower Clamp Bar	2	BB	Tie Strap	6
F	3/8" Self-Tapping Screw	6	CC	Valve Caps	2
G	3/8" Flat Washer	6	DD	5/16" Flat Washer	2
H	1/2" x 3/4" Flat Head Screw	2	EE	Rubber Washer	2
I	3/4" Hex Jam Nut	2	FF	5/16" Star Washer	2
J	1/8" Straight Fitting	2	GG	5/16" Hex Nut	4
K	3/4" Star Washer	2			

## Tools Needed

$\frac{1}{2}$ " ,  $\frac{9}{16}$ " , and  $\frac{3}{4}$ " open-end or box wrenches  
Crescent Wrench  
Ratchet with  $\frac{3}{8}$ " ,  $\frac{9}{16}$ " and  $\frac{1}{2}$ " deep well sockets  
 $\frac{5}{16}$ " and  $\frac{3}{8}$ " drill bits (very sharp)  
Heavy Duty Drill  
Torque Wrench

Hose Cutter, Razor Blade, or Sharp Knife  
Hoist or Floor Jacks  
Safety Stands  
Safety Glasses  
Air Compressor, or Compressed Air Source  
Spray Bottle with Dish Soap/Water Solution



**IMPORTANT:** Your vehicle may be equipped with a rear brake proportioning valve. Any type of load assist product could affect brake performance. We recommend that you check with your dealer before installing this type of product. If your vehicle DOES NOT have a rear brake proportioning valve or is equipped with an anti-lock type brake system, installation of a load assist product will have NO EFFECT ON BRAKE SYSTEM PERFORMANCE.

**IMPORTANT:** Failure to maintain correct minimum pressure (or pressure proportional to load), bottoming out, overextension, or rubbing against another component will void the warranty.

**DANGER:** Compressed air can cause injury and damage to the vehicle and parts if it is not handled properly. For your safety, do not try to inflate the air springs until they have been properly secured to the vehicle.



Figure 1

## I. Getting Started

1. Determine the Normal Ride Height. The Normal Ride Height is the distance between the bottom edge of the wheel-well and the center of the hub with the vehicle in the "as delivered" condition. In some cases, Normal Ride Height is not perfectly level.
  - a. Remove unusual loads and examine your vehicle from the side to ensure it is on a level surface (Figure 1).
  - b. If necessary (in cases where your leaf springs are sagging badly), use a jack to raise the rear end so that the vehicle achieves the original "as delivered" ride height.
2. Measure the distance between the center of the hub and the bottom edge of the wheel well (Figure 2). This is the Normal Ride Height. Enter the measurement below:

NORMAL  
RIDE HEIGHT: \_\_\_\_\_ inches



Figure 2

## II. Assembling the Air Spring Unit

1. Install the air fitting (J) to the top of the air sleeve (A). Tighten 1 and 1/2 turns (Figure 1).
2. Attach the lower bracket (C) to the bottom of the air sleeve (A) using the small flat head screw (H). Tighten securely (Figure 1).
3. Install the upper bracket (B) onto the top of the air sleeve, being sure to insert the air fitting through the hole on the bracket (Figure 1).
4. Install the nylon nut (I) and large star washer (K) to the top of the upper bracket by feeding it through the fitting. Leave loose at this time for later adjustment (Figure 1).
5. Repeat assembly for other sleeve.

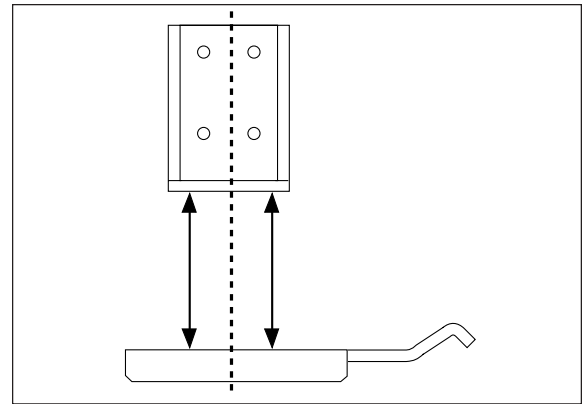

Figure 2

## III. Installing the Sleeve Assembly

1. Remove the tires. This kit should be mounted at normal ride height recorded on page 2.
2. Set the assembly on the leaf spring, rearward of the axle. The tab on the lower bracket should hook over the rearward leaf spring U-Bolt (Figure 1).
3. Attach the lower bracket to the leaf spring using U-Bolt (D) and clamp bar (E). Secure with flat washers (G) and lock nuts (L). Refer to Figure 1. Torque to 16 ft-lbs.
4. Ensure that there is at least 1/4" clearance between the roll plate and the closest part of the frame (Figure 4). The closer space will be rearward of the sleeve assembly.
5. Align the upper bracket so that it is parallel and perpendicular with the lower bracket (Figure 2).  
*NOTE: The upper bracket will be close to the jounce bumper bracket weld on the back side (Figure 3).*
6. Using the upper bracket as a template, mark any one of the holes on the upper bracket except the bottom rear hole (Figure 4).
7. Flip the air spring down away from the frame. Center punch the previously marked upper hole.
8. With the air spring still flipped down, drill the center punched hole location with a 5/16" drill bit.  
*NOTE: It is only necessary to drill through the outside sections of the frame to install the self-tapping hardware.*
9. Attach the upper bracket to the frame with one self-tapping screw (F). See Figure 1.

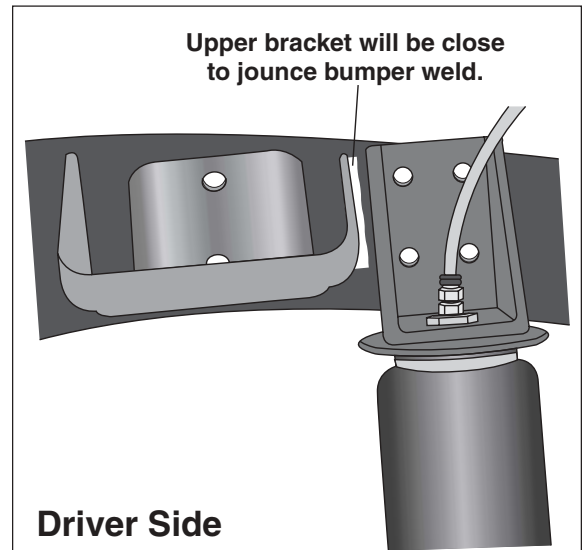

Figure 3

10. **IMPORTANT:** Be sure to cover the air fitting with piece of tape to prevent metal shavings from getting into the fitting or sleeve.
11. Check alignment, adjust if needed, then center punch and drill two more holes in the upper bracket.
12. Tighten the upper bracket mounting bolts (Figure 1). Do not overtighten.
13. Drill a  $\frac{3}{8}$ " hole through both sections of the frame.  
*CAUTION: Before drilling, check the back side of the frame to see if the brake lines, gas lines, or any other lines or wires need to be moved before drilling the upper bracket holes.*
14. Insert a  $\frac{3}{8}$ " bolt and washer through the bracket and the frame. Cap with a large washer and a nyloc nut.  
*NOTE: Tighten the bolt to the frame until snug, but do not overtighten. Overtightening can crush the frame section.*
15. Repeat steps 1-14 for the other side of the vehicle. Continue the installation by following the air line installation instructions.

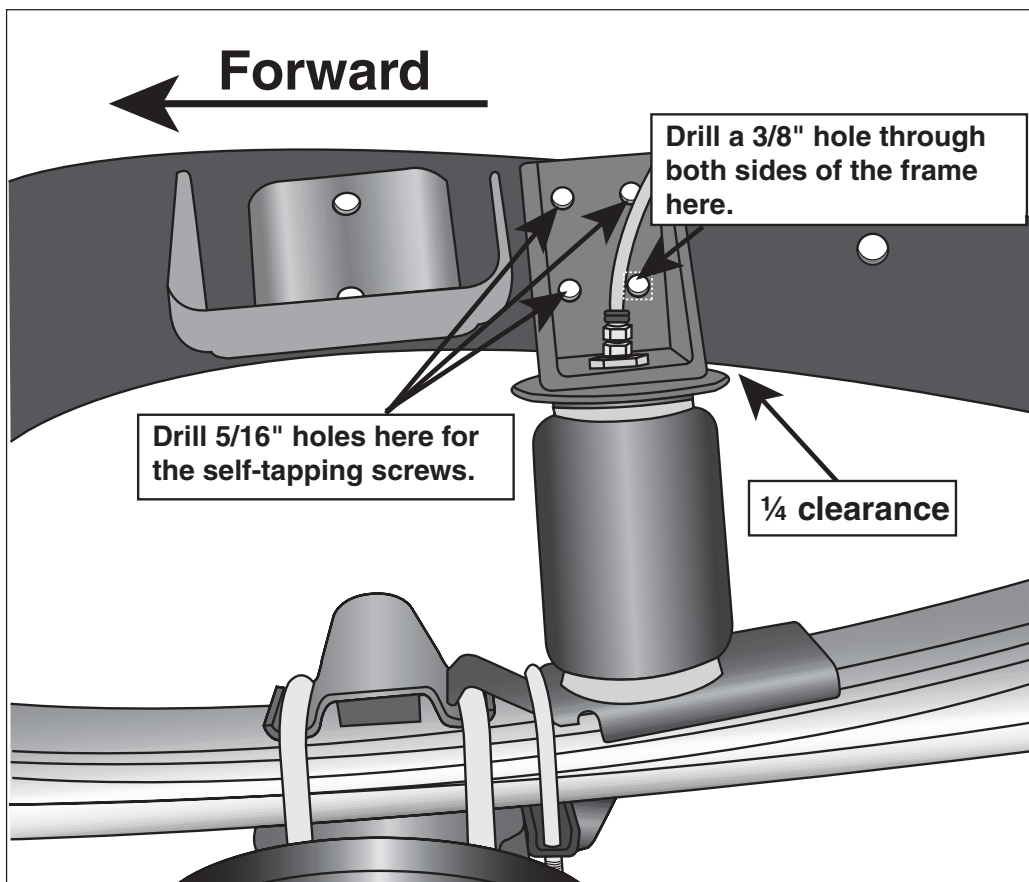

Figure 4

## IV. Installing the Air Lines

1. Choose a convenient location for mounting the inflation valves. Popular locations for the inflation valve are:
  - a. The wheel well flanges.
  - b. License plate recess in bumper.
  - c. Under the gas cap access door.
  - d. Through license plate itself.

*NOTE: What ever the chosen location is, make sure there is enough clearance around the inflation valves for an air chuck.*



Figure 5

2. Drill a  $\frac{5}{16}$ " hole to install the inflation valves.
3. Cut the air line assembly (AA) in two equal lengths (Figure 5).

*CAUTION: When cutting or trimming the air line, use a hose cutter (Air Lift P/N 10530), a razor blade or a sharp knife. A clean, square cut will ensure against leaks. (Figure 6). Do not use wire cutters or scissors to cut the air line. These tools may flatten or crimp the air line, causing it to leak around the O-ring seal inside the elbow fitting (Figure 6).*

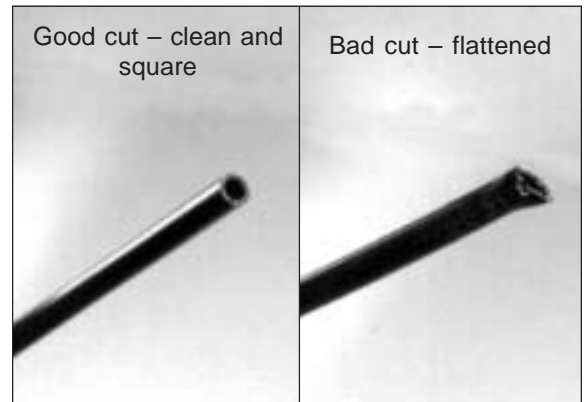

Figure 6

4. Place a  $\frac{5}{16}$ " nut (GG) and a star washer (FF) on the air valve. Leave enough of the inflation valve in front of the nut to extend through the hole and have room for the rubber washer (EE), flat washer (DD), and  $\frac{5}{16}$ " nut (GG) and cap (CC). There should be enough valve exposed after installation - approximately  $\frac{1}{2}$ " - to easily apply a pressure gauge or an air chuck (Figure 7).
5. Push the inflation valve through the hole and use the rubber washer (EE), flat washer (DD), and another  $\frac{5}{16}$ " nut (GG) to secure it in place. Tighten the nuts to secure the assembly in place (Figure 8).
6. Route the air line along the frame to the air fitting on the air spring. Keep at least 6" of clearance between the air line and heat sources, such as the exhaust pipes, muffler, or catalytic converter. Avoid sharp bends and edges. Use the plastic tie straps (BB) to secure the air line to fixed, non-moving points along the chassis. Be sure that the tie straps are tight, but do not pinch the air line. Leave at least 2" of slack to allow for any movement that might pull on the air line.
7. Cut off air line leaving approximately 12" of extra air line. A clean square cut will ensure against leaks.
8. To properly instal the airline, measure  $\frac{9}{16}$ " from the cut end and mark with tape. Lubricate (i.e. soap solution, silicone spray, saliva) the end of the air line and insert it into the fitting. This is a push to connect fitting. A click can be heard/felt when the air line is seated, also, the front edge of the tape band should be flush with the fitting. The air line is now installed.



Figure 7

## V. Finishing the Installation

1. With the air line in the fitting, inflate to 10 p.s.i., adjust the sleeve in or out for alignment, and secure air sleeve to upper bracket by tightening the nylon nut to 4 ft-lbs (Figure 1). Do not overtighten.
2. Repeat entire installation procedures for the remaining side.
3. After both sides are complete, continue by reading Sections VI through X.

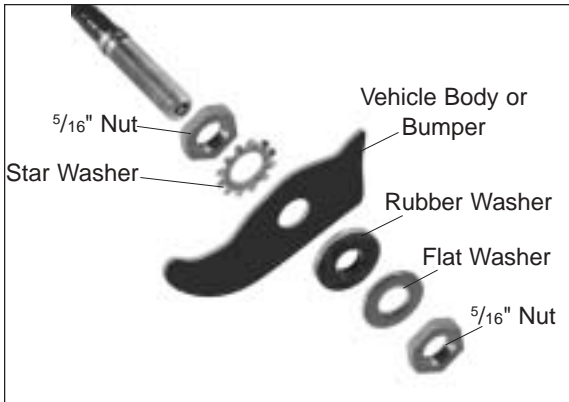

Figure 8

## VI. Maintenance and Operations

Minimum Air Pressure	Maximum Air Pressure
10 p.s.i.	100 p.s.i.
<i>Failure to maintain correct minimum pressure (or pressure proportional to load), bottoming out, over-extension, or rubbing against another component will void the warranty.</i>	

By following these steps, vehicle owners will obtain the longest life and best results from their air springs.

1. Check the air pressure weekly.
2. Always maintain Normal Ride Height. Never inflate beyond 100 p.s.i.
3. If you develop an air leak in the system, use a soapy water solution to check all air line connections and the inflation valve core before deflating and removing the air spring.
4. When increasing load, always adjust the air pressure to maintain the Normal Ride Height. Increase or decrease pressure from the system as necessary to attain Normal Ride Height for optimal ride and handling. Remember that loads carried behind the axle (including tongue loads) require more leveling force (pressure) than those carried directly over the axle.
5. **IMPORTANT:** For your safety and to prevent possible damage to your vehicle, *do not exceed maximum Gross Vehicle Weight Rating (GVWR), as indicated by the vehicle manufacturer.* Although your air springs are rated at a maximum inflation pressure of 100 p.s.i. The air pressure actually needed is dependant on your load and GVWR, which may be less than 100 p.s.i. Check your vehicle owners manual and do not exceed the maximum load listed for your vehicle.
6. Always add air to springs in small quantities, checking the pressure frequently. Sleeves require less air volume than a tire and inflate quickly.
7. *Should it become necessary to raise the vehicle by the frame, make sure the system is at minimum pressure (10 p.s.i.) to reduce the tension on the suspension/brake components. Use of on-board leveling systems do not require deflation or disconnection.*

### **Thank you for purchasing Air Lift Products**



Mailing Address:  
AIR LIFT COMPANY  
P.O. Box 80167  
Lansing, MI 48908-0167

Street Address:  
AIR LIFT COMPANY  
2727 Snow Rd.  
Lansing, MI 48917

Local Phone: (517) 322-2144

Fax: (517) 322-0240

<http://www.airliftcompany.com>

For Technical Assistance call 1-800-248-0892

***“The Choice of the Professional Installer”***

Printed in the USA