

2360 Boswell Road
Chula Vista, CA 91914
Phone 619.216.1444
Fax 619.216.1474
E-Mail tech@explorerprocomp.com

Latest revision

**Date:
8.9.13**



PRO COMP SUSPENSION

Suspension Systems that Work!

NOTE: This kit can be used in conjunction with any Pro Comp 0" to 8" lift kit

**Part # 2581
1999-2004 4WD Ford
F250/F350
Dual Steering
Stabilizer Bracket
Kit**

This document contains very important information that includes warranty information and instructions for resolving problems you may encounter. Please keep it in the vehicle as a permanent record.

- ◆ **This installation requires a professional mechanic!**
- ◆ We recommend that you have access to a factory service manual for your vehicle to assist in the disassembly and reassembly of your vehicle. It contains a wealth of detailed information.
- ◆ Prior to installation, carefully inspect the vehicle's steering and driveline systems paying close attention to the tie rod ends, ball joints, wheel bearing preload, pitman and idler arm. Additionally, check steering-to-frame and suspension-to-frame attaching points for stress cracks. The overall vehicle must be in excellent working condition. Repair or replace all worn or damaged parts!
- ◆ Read the instructions carefully and study the illustrations before attempting installation! You may save yourself a lot of extra work.
- ◆ Check the parts and hardware against the parts list to assure that your kit is complete. Separating parts according to the areas where they will be used and placing the hardware with the brackets before you begin will save installation time.
- ◆ Check the special equipment list and ensure the availability of these tools.
- ◆ Secure and properly block vehicle prior to beginning installation.
- ◆ ***ALWAYS*** wear safety glasses when using power tools or working under the vehicle!
- ◆ Use caution when cutting is required under the vehicle. The factory undercoating is flammable. Take appropriate precautions. **Have a fire extinguisher close at hand.**
- ◆ Foot pound torque readings are listed on the Torque Specifications chart at the end of the instructions. These are to be used unless specifically directed otherwise. Apply thread lock retaining compound where specified.
- ◆ *Please note that while every effort is made to ensure that the installation of your Pro Comp lift kit is a positive experience, variations in construction and assembly in the vehicle manufacturing process will virtually ensure that some parts may seem difficult to install. Additionally, the current trend in manufacturing of vehicles results in a frame that is highly flexible and may shift slightly on disassembly prior to installation. The use of pry bars and tapered punches for alignment is considered normal and usually does not indicate a faulty product. However, if you are uncertain about some aspect of the installation process, please feel free to call our tech support department at the number listed on the cover page. We do not recommend that you modify the Pro Comp parts in any way as this will void any warranty expressed or implied by the Pro Comp Suspension company.*

Optional Equipment Available from your Pro Comp Distributor!

22415 REAR LEAF SPRINGS,
LIGHTS,
52480 CARRIER BEARING SHIM KIT,
599 ALIGNMENT CAM KIT,
50191 U-Bolt Kit,
PN 72400: TRACTION BARS, PN 72099: TRACTION BAR MOUNTING KIT
99-400: 4 DEGREE REAR AXLE SHIM KIT

Also, check out our outstanding selection of Pro Comp tires
to compliment your new installation!

Part #	Description	Qty.	Illus.	Page
91-5358	CENTER BRACKET	1	1	4
91-5359	DRVR SIDE STABILIZER MOUNT BRACKET: Upper 1	1	2	4
91-5360	DRVR SIDE STABILIZER MOUNT BRACKET: Lower 1	1	2	4
020106	HARDWARE PACK: 3/8" U-bolt	1	1	4
90-6253	HARDWARE PACK: Center Bracket	1	-	-
70-0503001800	1/2" X 3" Gr. 8 HEX BOLT	2	2	4
72-05000100816	1/2" USS Gr. C STOVER NUT	2	2	4
73-05000030	1/2" Gr. 8 HARDENED FLAT WASHER	4	2	4
90-6677	HARDWARE PACK: Center Bracket	1	-	-
70-0506501800	1/2"-13 X 6 1/2" Gr. 8 HEX BOLT	1	2	4
73-05000034	1/2" SAE Gr. 8 FLAT WASHER	2	2	4
72-050100816	1/2" Gr. 8 STOVER NUT	1	2	4
90-2524	STABILIZER SPACER: Center Bracket	3	2,3	4
54314	STABILIZER SLEEVE	4		
Suggested Steering Stabilizers:				
ES226000	STEERING STABILIZER X2	2	2,3	4
ZX2905	STEERING STABILIZER X2	2	2,3	4

INSTALLATION INSTRUCTIONS:

- Position your vehicle on a smooth, flat, hard surface (i.e. concrete or asphalt). Block the rear tires and set the emergency brake.
- Remove the factory steering stabilizer and bracket from the vehicle and discard.
- Remove the front (2) hi nuts and washers from the driver side axle U-bolts.
- Install the driver side stabilizer mount brackets (**91-5359 upper** and **91-5360 lower**) to the front driver side U-bolts. Reinstall the previously removed hi-nuts and washers and torque to 105 ft./lbs. See ILLUSTRATION 2.
NOTE: Installation of these brackets may require the use of longer U-bolts. (sold separately)
- Using a paint pen, mark the relationship of the adjustment sleeve and the driver side tie rod to make sure the adjustment sleeve does not move.
- Remove the adjustment sleeve safety lock from the adjustment sleeve and pass side tie rod end.
- Loosen the (2) nuts and rotate the lock clamps on the adjustment sleeve. The nuts will need to face up for clearance. ***DO NOT*** rotate the adjustment sleeve itself.
- Reinstall the adjustment sleeve safety lock to the adjustment sleeve and pass side tie rod with the nut facing up. Torque all clamps and sleeve bolts to factory specifications. **Note:** On the passenger side you may need to drill the OE mount to 1/2".
- Install **54314** in to both ends of the stabilizers.
- Bolt the shaft end of the stabilizer to the existing mounting hole in the axle on the passenger side and the newly installed stabilizer mount brackets on the driver side using the supplied **1/2" X 3"** bolts (heads of the bolts facing up) and hardware. Torque the **1/2"** mounting bolt hardware

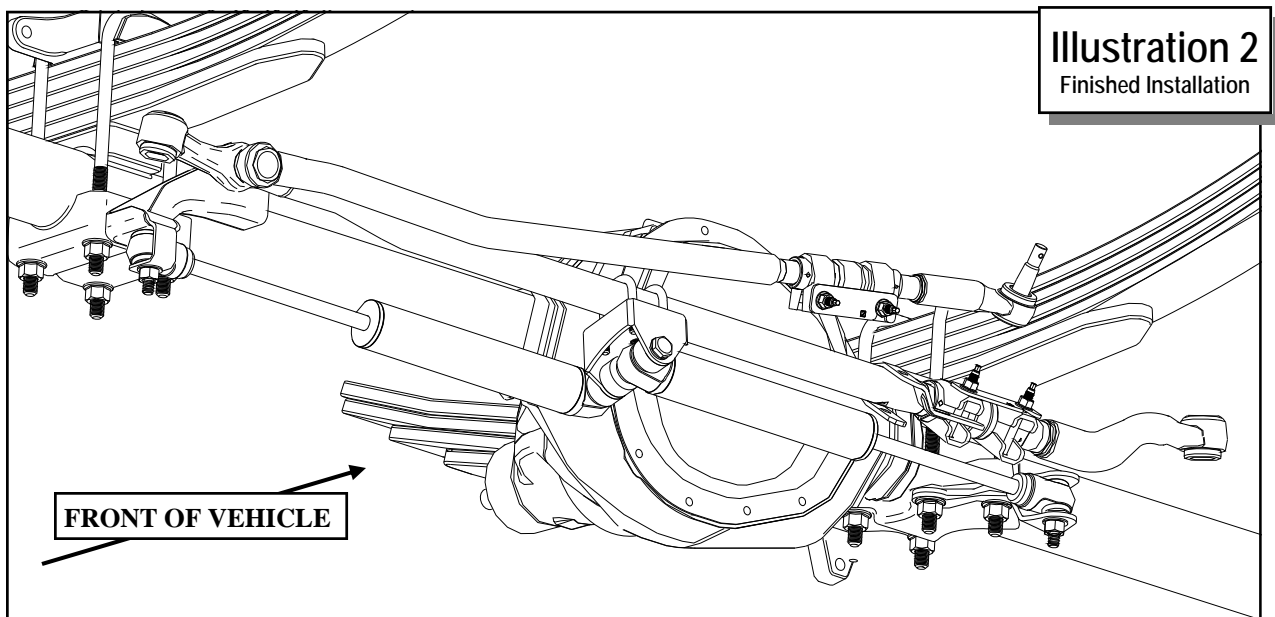
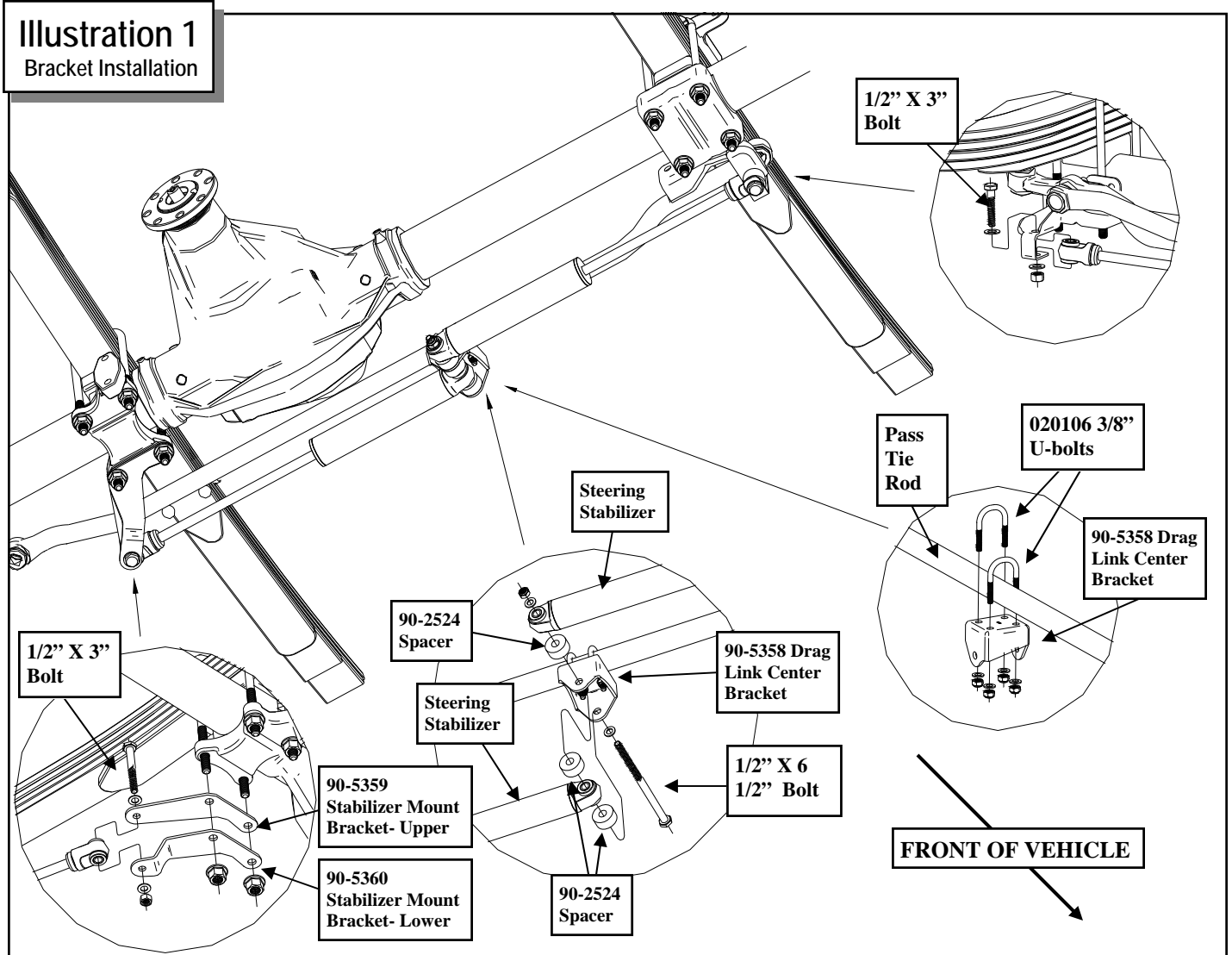

according to the torque chart on page 5.
See ILLUSTRATION 2,3.

NOTE: If the outside mounting bolt on the driver side hits the tie rod, the cast lower U-bolt plate will need to be adjusted. Loosening up the front U-bolt hi nuts and tightening up the rear U-bolts hi nuts will allow the cast plate to be adjusted, so the stabilizer mount brackets can be moved down. There must be at least a 1/4" of space between the tie rod and the bolt at full steering lock.

11. With the front wheels centered under the vehicle, center the stabilizer center bracket (91-5358) under the vehicle. Hold the center bracket against the pass side rod. See ILLUSTRATION 1.
12. Install the 3/8" U-bolts from pack (020106) over the pass side tie rod and through the center bracket (91-5358). See

ILLUSTRATION 1. Be sure the bracket is level and torque the 3/8" U-bolt hardware according to the torque chart below.

13. Insert the body end of the steering stabilizers, with the brass fitting up, to the center bracket (91-5358) using the supplied 1/2" X 6 1/2" shock bolt (head of the bolt facing the front of the vehicle), (3) spacers (90-2524) and 1/2" hardware. See ILLUSTRATION 1. Torque the 1/2" mounting bolt hardware according to the torque chart below.
14. With the wheels centered, check that the bracket is centered and cycle the steering full left and full right to assure there are no binding, clearance issues or bottoming out and/or over extension of the stabilizers.
15. Re-torque all the newly installed hardware after 100 miles or any off road use.

Use this only as a guide for hardware without a called out torque specification in the instruction manual.

Bolt Torque and ID						
Decimal System			Metric System			
All Torques in Ft. Lbs. Maximums						
Bolt Size	Grade 5	Grade 8	Bolt Size	Class 9.8	Class 10.9	Class 12.9
5/16	15	20	M6	5	9	12
3/8	30	45	M8	18	23	27
7/16	45	60	M10	32	45	50
1/2	65	90	M12	55	75	90
9/16	95	130	M14	85	120	145
5/8	135	175	M16	130	165	210
3/4	185	280	M18	170	240	290

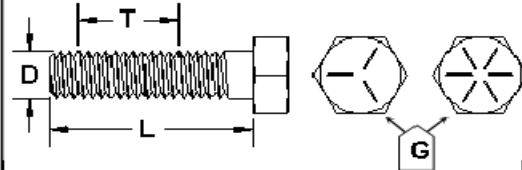
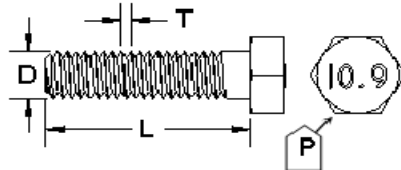
			
<p>1/2-13x1.75 HHCS</p> <p>D T L X</p>	<p>M12-1.25x50 HHCS</p> <p>D T L X</p>		
<p>Grade 5 Grade 8</p> <p>(No. of Marks + 2)</p>	<p>P</p>		
<p>G = Grade (Bolt Strength) D = Nominal Diameter (Inches) T = Thread Count (Threads per Inch) L = Length (Inches) X = Description (Hex Head Cap Screw)</p>		<p>P = Property Class (Bolt Strength) D = Nominal Diameter (Millimeters) T = Thread Pitch (Thread Width, mm) L = Length (Millimeters) X = Description (Hex Head Cap Screw)</p>	

Notice to Owner operator, Dealer and Installer:

Vehicles that have been enhanced for off-road performance often have unique handling characteristics due to the higher center of gravity and larger tires. This vehicle may handle, react and stop differently than many passenger cars or unmodified vehicles, both on and off-road. You must drive your vehicle safely! Extreme care should always be taken to prevent vehicle rollover or loss of control, which can result in serious injury or even death. Always avoid sudden sharp turns or abrupt maneuvers and allow more time and distance for braking! Pro Comp reminds you to fasten your seat belts at all times and reduce speed! We will gladly answer any questions concerning the design, function, maintenance and correct use of our products.

Please make sure your Dealer/Installer explains and delivers all warning notices, warranty forms and instruction sheets included with Pro Comp product.

Application listings in this catalog have been carefully fit checked for each model and year denoted. However, Pro Comp reserves the right to update as necessary, without notice, and will not be held responsible for misprints, changes or variations made by vehicle manufacturers. Please call when in question regarding new model year, vehicles not listed by specific body or chassis styles or vehicles not originally distributed in the USA.

Please note that certain mechanical aspects of any suspension lift product may accelerate ordinary wear of original equipment components. Further, installation of certain Pro Comp products may void the vehicle’s factory warranty as it pertains to certain covered parts; it is the consumer’s responsibility to check with their local dealer for warranty coverage before installation of the lift.

Warranty and Return policy:

Pro Comp warrants its full line of products to be free from defects in workmanship and materials. Pro Comp’s obligation under this warranty is limited to repair or replacement, at Pro Comp’s option, of the defective product. Any and all costs of removal, installation, freight or incidental or consequential damages are expressly excluded from this warranty. Pro Comp is not responsible for damages and / or warranty of other vehicle parts related or non-related to the installation of Pro Comp product. A consumer who makes the decision to modify his vehicle with aftermarket components of any kind will assume all risk and responsibility for potential damages incurred as a result of their chosen modifications. Warranty coverage does not include consumer opinions regarding ride comfort, fitment and design. Warranty claims can be made directly with Pro Comp or at any factory authorized Pro Comp dealer.

IMPORTANT! To validate the warranty on this purchase please be sure to mail in the warranty card.

Claims not covered under warranty-

- Parts subject to normal wear, this includes bushings, bump stops, ball joints, tie rod ends and heim joints
 - Discontinued products at Pro Comp’s discretion
- Bent or dented product
- Finish after 90 days
- Leaf or coil springs used without proper bump stops
- Light bulbs
- Products with evident damage caused by abrasion or contact with other items
- Damage caused as a result of not following recommendations or requirements called out in the installation manuals
- Products used in applications other than listed in Pro Comp’s catalog
- Components or accessories used in conjunction with other manufacturer’s systems
- Tire & Wheel Warranty as per Pro Competition Tire Company policy
- Warranty claims without “Proof of Purchase”
- Pro Comp Pro Runner coil over shocks are considered a serviceable shock with a one-year warranty against leakage only. Rebuild service and replacement parts will be available and sold separately by Pro Comp. Contact Pro Comp for specific service charges.
- Pro Comp accepts no responsibility for any altered product, improper installation, lack of or improper maintenance, or improper use of our products.

E-Mail: tech@explorerprocomp.com
Website: www.explorerprocomp.com
Fax: (619) 216-1474
Ph: (619) 216-1444

PLACE
WARRANTY REGISTRATION
NUMBER
HERE: _____