



Hella Ultimate Style/Black Magic Driving Lamp System INSTALLATION INSTRUCTIONS

Lit. # 55205 12942.5

Congratulations! You are now the proud owner of the world's most unique high performance driving lamps!

The Hella Black Magic Driving Lamp System

uses Hella's innovative Black Optics™ Technology to create the all black look and an extremely powerful and efficient beam of light. The integrated black sport optic sight between the reflector and lens eliminates any stray light to deliver an enhanced-focus beam. The sight's reflection in the highly polished metal reflector produces the all black look when the lamp is "off".

For off-road use only.

Kit Contents

Before assembly, please check and familiarize yourself with the contents of your Hella Black Magic Driving Lamp Kit.

Contents:

- (2) Hella Black Magic lens/housing assemblies with H2 Halogen bulbs
- (1) Complete wiring system with 12V/30A relay, in-line fuse holder and 15A fuse
- (2) Sets of mounting brackets and installation parts
- (2) Female spade connectors
- (2) Insulated female spade connectors
- (3) Metal screws
- (2) "Scotch-lock™" connectors

- (1) Illuminated rocker switch
- (2) Cable straps
- (2) Rubber grommets

Tools Required

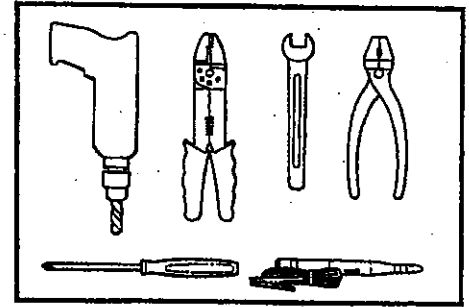

- Electric drill
- 1/8" (3mm), 13/32" (10mm) and 1/2" (13mm) diameter drill bits
- 1/2" (13mm) and 11/16" (17mm) wrenches
- Phillips screwdriver
- Wire crimper
- Pliers
- Tape measure or ruler
- Circuit tester

Preparation

1. Please read and follow all instructions carefully to make sure you have a proper and legal installation.
2. Consult your local and state regulations regarding minimum and maximum mounting height above ground.

3. For maximum performance and efficiency, make certain that your vehicle's standard lighting is properly aimed.
4. Determine the best mounting position for your vehicle.
5. Mount both of your lamps at the same height. Position the lamps at an equal distance from the center of the vehicle.
(See Fig. 1)

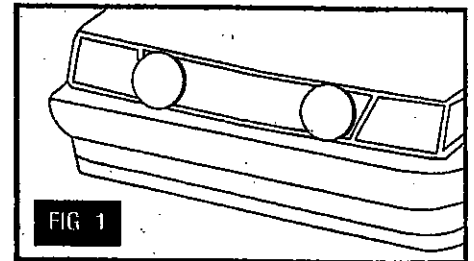

CAUTION: Make sure auxiliary lamps do not restrict airflow to the radiator or obstruct headlamps, turn signals or marker lamps.

Mounting

1. Attach mounting base to lamp housing. Do not tighten completely until wiring is finished and lamps are properly aimed. (See Fig. 2)
2. Mark mounting points on bumper and drill 13/32" (10mm) dia. holes.

3. Attach lamp base to bumper. Do not tighten completely until lamp is properly aimed. (See Fig. 3)

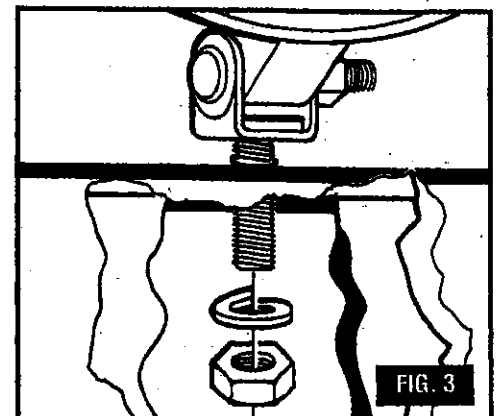
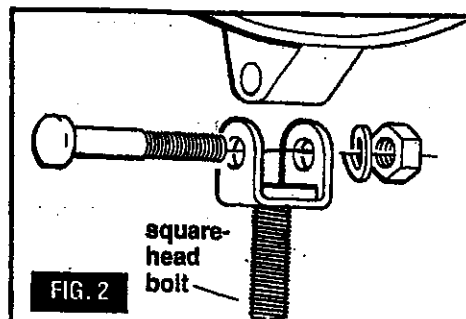

Wiring Harness Installation

1. Locate high beam power (+) lead of one headlamp by using a circuit tester. Use the following procedure:

- Turn on headlamps and activate high beams.
- Connect the end of the circuit tester to ground (-) and use the tester to locate the headlamp high beam lead. The test lamp will indicate when contact is made with the high beam lead.
- Turn off ignition and headlamps.
- Disconnect battery.

2. Refer to Fig. 4 for diagram of wiring procedure.

Note: The Hella Wiring System supplied with this kit is a complete assembly. It is fully insulated and sleeved. All connections are pre-terminated except for the wire ends, which will connect to the auxiliary lamps.

3. Mount relay as follows: (See A in Fig. 4)

- Position relay upright on battery side of the engine compartment in an area that is not exposed to water spray, excessive heat or moving parts.
- Make sure the relay is mounted close enough to the battery so the power lead (red) will easily reach the positive (+) terminal of the battery.

4. Connect relay power lead to battery as follows: (See B in Fig. 4)

- Route the power lead (red with in-line fuse) to the positive (+) battery terminal bolt. Attach the red wire to the battery terminal bolt.

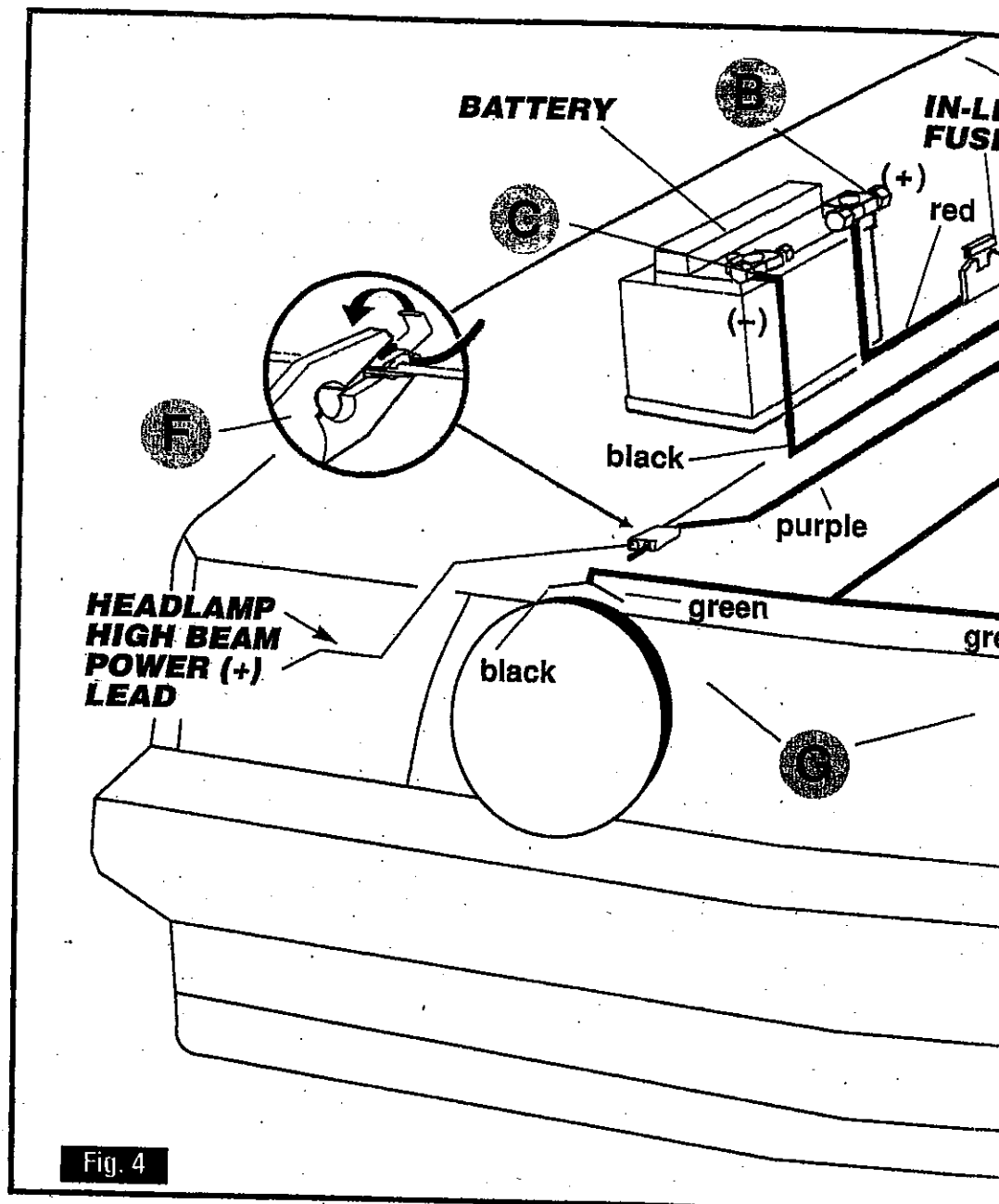

Fig. 4

b. Connect ground wire (black) to ground or to the negative (-) battery terminal. (See C in Fig. 4) Use screw (provided) if necessary.

5. Route wires to switch as follows: (See D in Fig. 4)

- Find an unused grommet in the engine firewall. If an unused grommet cannot be found, drill a 13/32" hole in an area with clear access to both sides.

Note: The three wire leads for the switch are taped together for easier routing through the firewall.

b. Route the taped portion of the harness to the location of the switch by going through the grommet (or hole you've drilled) in the firewall into the vehicle interior. Remove tape after routing is complete.

6. Install switch as follows: (See E in Fig. 4)

- Select a location for the switch (i.e. dashboard or center console). Make sure there is sufficient space to install the switch and that there are no components or wires

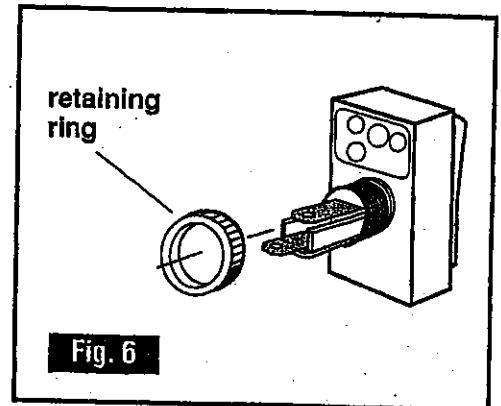
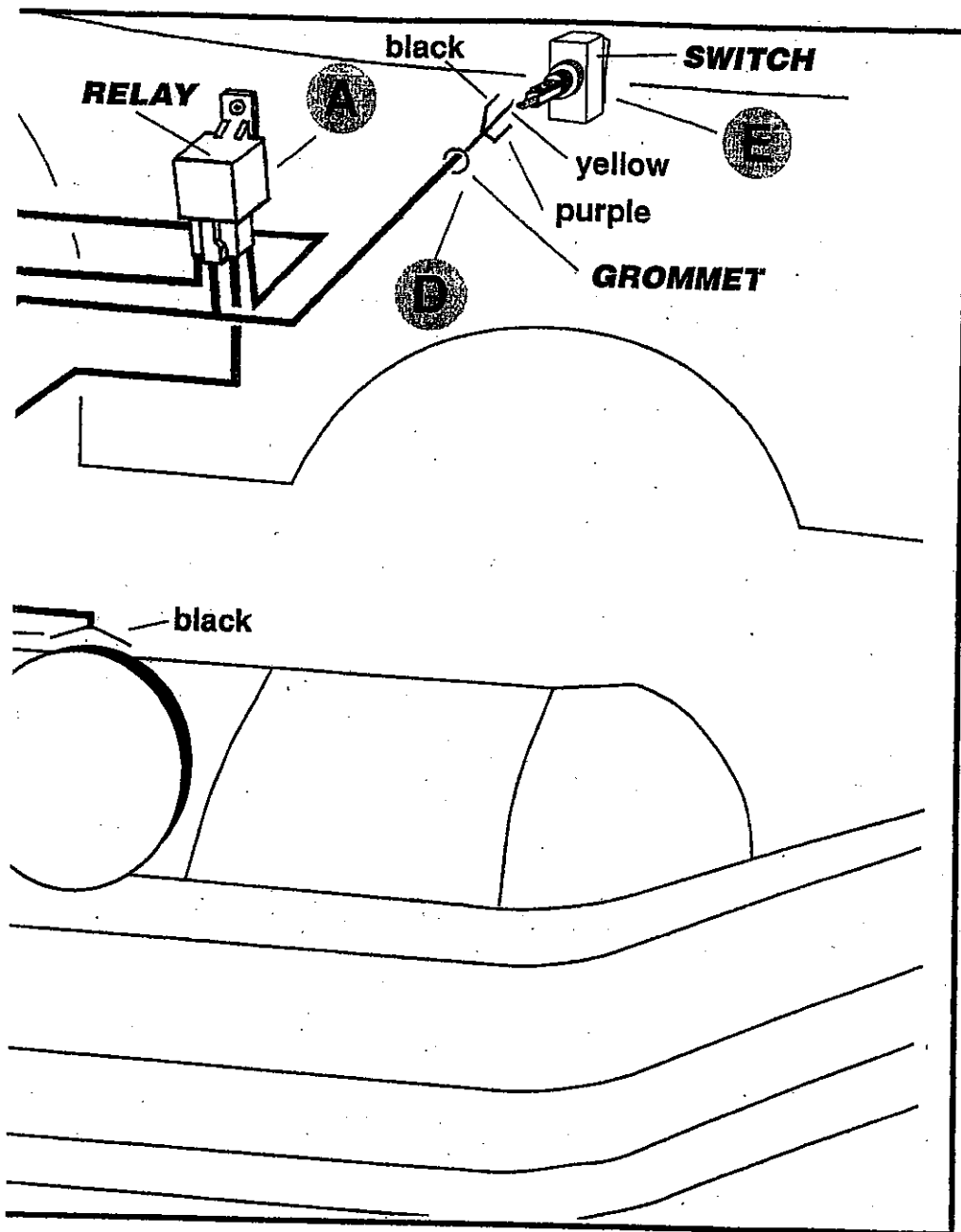

g. Similarly, connect the purple wire to the terminal on the switch marked "supply" and the yellow wire to the terminal marked "load". (See Fig. 7).

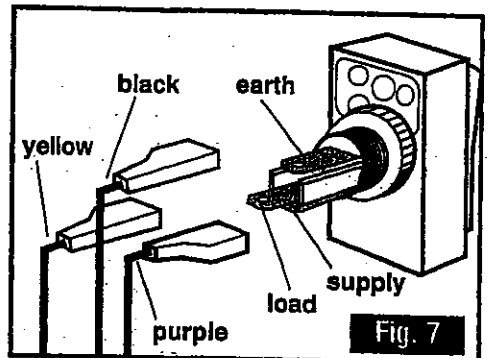

7. Connect auxiliary lamp power (+) lead (purple) as follows:
(See F in Fig. 4)

- a. Route the single purple wire to high beam power (+) lead of one headlamp.
- b. Attach purple wire to high beam lead with "Scotch-lock" connector. (See inset F in Fig. 4)

8. Route harness to auxiliary lamps as follows: (See G in Fig. 4)

Route the two sets of auxiliary lamp leads [each has one green power (+) and one black ground (-) wire] to the auxiliary lamps. **Note:** Route the shorter lead to the lamp on the battery side and the longer lead to the lamp on the opposite side.

behind the mounting surface area which would be damaged when drilling.

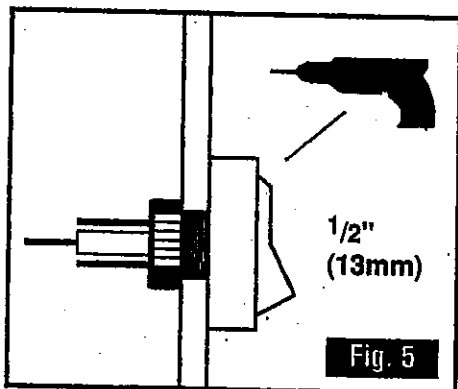

b. Drill a mounting hole with 1/2" (13mm) dia. drill bit and install illuminated switch. (See Fig. 5)

c. Unscrew retaining ring. (See Fig. 6)

d. Slide switch through mounting hole. (See Fig. 5)

e. Secure switch with retaining ring. (See Fig. 5)

f. Connect black wire by sliding its female spade connector to the top spade terminal marked "earth".

Lamp Wiring

Connect wiring harness leads to auxillary lamps as follows;

Note: All wires must be routed before terminals are attached.

(See Fig. 8)

1. Open lamp assemblies, use Phillips screwdriver to remove the screws at the bases of the lamps. (See Fig. 8)

2. Route green and black wires to each lamp through opening in back of lamp housing. Thread wires through rubber grommet

(provided) and insert grommet into housing. The flat side of the grommet should be inside the lamp housing. All wires must be routed before terminals are attached. (See Fig. 8)

3. Crimp terminals to wire leads as follows: crimp the un-insulated female spade connectors to the black wires; crimp the blue insulated female spade connectors to the green wires.

4. Connect green and black leads to spade terminals at bulb's base; green lead to thicker terminal;

black lead (the ground) to the thinner spade terminal. Ignore (or remove) pink wire inside lamp housing. (See Fig. 8)

IMPORTANT: When it is time to replace the halogen bulbs, do not touch the new bulbs with bare hands as this will reduce bulb life. If bulbs are touched accidentally, clean them with tissue and rubbing alcohol.

5. Assemble lamps and re-install Phillips screws.

Note: Lamps come pre-assembled for upright mounting.

6. Use wire ties (provided) to secure any slack portion of the harness in the engine compartment away from moving parts or excessive heat.

7. Test operation of lights as follows:

a. Re-connect battery.

b. Turn on ignition switch and headlamp. Activate high beams.

c. Switch on Black Magic Driving Lights. If they do not illuminate, check fuse and all wiring connections.

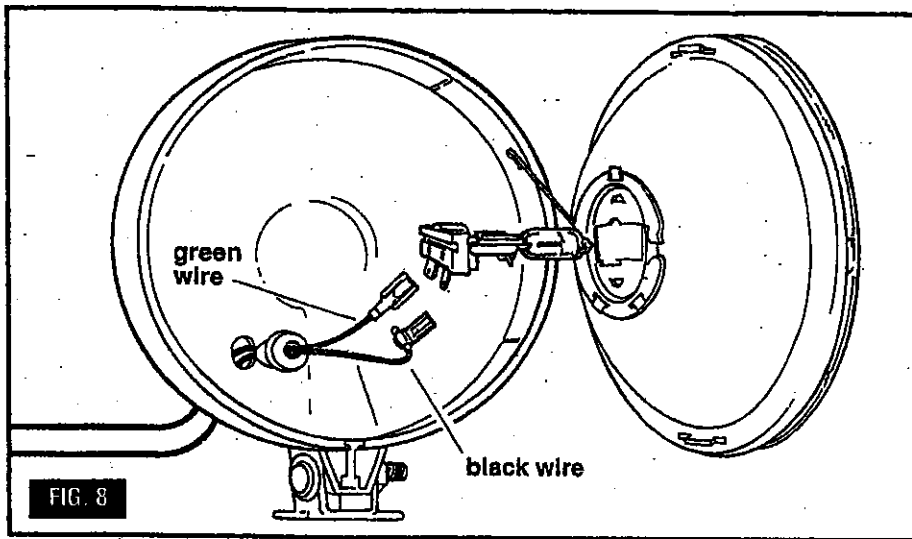

Lamp Aiming

1. Adjust position of driving lamps by pivoting lamp housing in vertical or horizontal direction. (See Fig. 9)

2. Aim lamps. (See Fig. 10) Position vehicle on flat surface at

a distance of 25' (7.6 m) from wall. Measure the distance from center of the driving lamp to the ground and mark off the same height on wall.

3. Turn on lamps and adjust them so center of beam is even with mark on the wall (lamp center line).

4. Tighten both nuts on mounting base to secure lamps in place. (See Fig. 2 and 3)

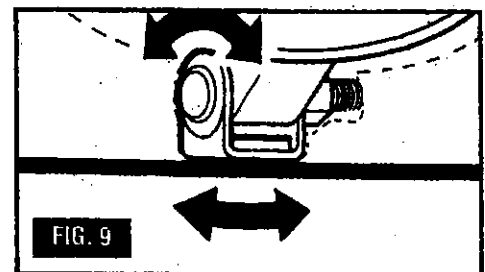
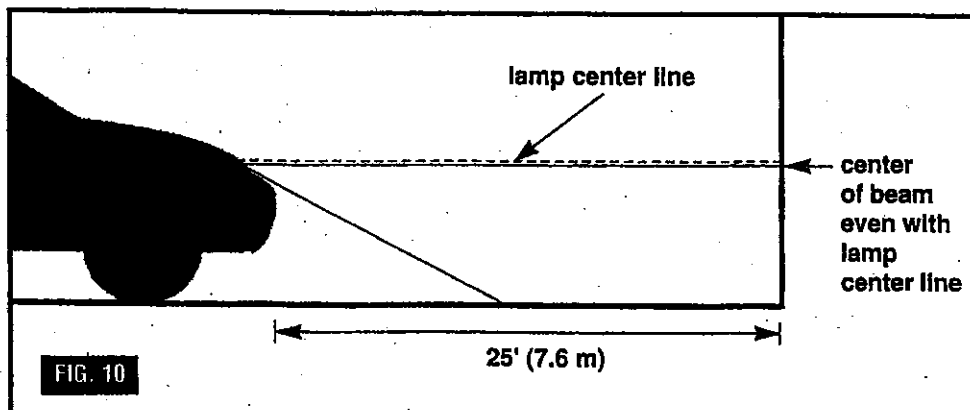

If you have any questions or problems, please consult your local authorized technician or call Delta Customer Service, Delta, Inc., 20 Kohn Blvd., Bannockburn, IL 60015, (800) 247-5924, FAX (800) 637-1575.